



Low voltage AC drives

ABB industrial drives ACS880, single drives 0.75 to 1700 hp (0.55 to 1300 kW) Catalog

Power and productivity
for a better world™



What does all-compatible mean for you?

Being all-compatible means that drive choice should add value to your business. Drives should meet the unique demands of your processes, help you save energy and reduce operating costs. Also, all-compatible means that our drives are easy to select, use and maintain. These are the cornerstones making our industrial drive series the all-compatible choice.

Contents

3	The all-compatible ACS880 series drives
4	Simplifying your world without limiting your possibilities
5	Single drives, ACS880
6	Human all-compatible
7	Process all-compatible
8	Environment all-compatible
9	Business all-compatible
10	How to select a drive
10	Technical data
11	Wall-mounted single drives, ACS880-01
12-13	Ratings, types and voltages, ACS880-01
14	Cabinet-built single drives, ACS880-07
15	Ratings, types and voltages, ACS880-07
16	Standard interface and extensions for comprehensive connectivity
17	Standard software for scalable control and functionality
18	Ready made programs for application control
19	Intuitive human-machine interface
20	PC tool for easy startup and maintenance
21	Integrated safety simplifies configuration
22	Drive application programming with CODESYS
23	Flexible connectivity to automation networks
24	Input/output extension modules for increased connectivity
24	Speed feedback interfaces for precise process control
24	DDCS communication option modules
25	EMC – electromagnetic compatibility
26	Brake options
27-28	Brake options, ACS880-01
28	Brake options, ACS880-07
29-30	du/dt filters
31	Dimensioning tool for selecting the optimal drive
32-33	Summary of features and options
34	Expertise at every stage of the value chain
35	Secure uptime throughout the drive life cycle

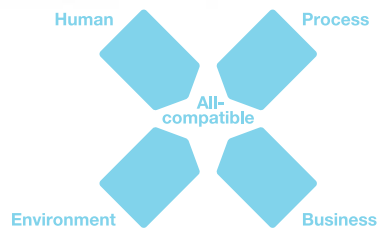

The all-compatible ACS880 series drives

The ACS880 series drives are part of ABB's all-compatible drives portfolio. Compatible with virtually all types of processes, automation systems, users and business requirements they are designed to tackle any motor-driven application, in any industry, whatever the power range. The innovation behind all-compatibility is our new drives architecture that simplifies operation, optimizes energy efficiency and helps maximize process output. The ACS880 series consists of single drives, multidrives and drive modules.

Simplifying your world without limiting your possibilities

Drive application programming
Customizable to meet the precise application needs using CODESYS programming. The drive is also easy to integrate with other ABB components such as PLC and HMI.



Wide range of safety features

Safe torque off is built-in as standard. An optional safety functions module provides extended safety functions, simplifying the configuration and reducing installation space.



Direct torque control (DTC)

ABB's signature motor control technology provides precise speed and torque control for all applications and virtually any type of AC motor.



Application control programs

A range of ready-made programs to optimize application productivity and usability.



Removable memory unit

Stores all the software and parameter configurations in an easily replaceable and simple-to-install module.

Energy efficiency

The drive provides features such as an energy optimizer and energy efficiency information that help you monitor and save energy used in the processes.



Single drives, ACS880

The all-compatible drives are designed to provide customers across industries and applications with unprecedented levels of compatibility and flexibility.

Our ACS880 single drives are stand alone drives. They are customized to meet the precise needs of industries such as oil and gas, mining, metals, chemicals, cement, power plants, material handling, pulp and paper, sawmills and marine. They control a wide range of applications such as cranes, extruders, winches, winders, conveyors, mixers, compressors, pumps and fans.



Intuitive human-machine interface

Intuitive, high-contrast and high-resolution display enabling easy navigation in multiple languages.



Startup and maintenance tool

PC tool for drive startup, configuration and daily use and process tuning. PC tool is connected to the drive via Ethernet or USB interface.



Communication with all major automation networks

Fieldbus adapters enable connectivity with all major automation networks.



Extended connectivity

In addition to the standard interfaces, the drive has three built-in slots for additional input/output extension modules and speed feedback interfaces.

Flexible product configurations

Drives are built to order with a wide range of options such as EMC filters, braking options and different enclosure variants.



Human all-compatible

The new drives share easy-to-use interfaces saving you time during drive commissioning and maintenance. When you have learned it once, you can use it with all the drives in our all-compatible drives portfolio.

The new control panel supports over 20 languages. The new PC tool provides extensive drive monitoring capabilities and quick access to the drive settings. Integrated and certified safety features provide safety for machine operators.





Process all-compatible

The drives are compatible with all kinds of processes. They control virtually any type of AC motor, provide extensive input/output connectivity and support all major fieldbus protocols. The drives cover a wide voltage and power range. Control performance is scalable from basic to demanding applications delivered by direct torque control (DTC). The flexibility and scalability of the drives enable one drive platform to control virtually any application or process, making your drive selection easy.



Environment all-compatible

There is an increased demand for reducing industries' impact on the environment. Our drives can help you reduce energy consumption in a wide range of applications. The new drives have an energy optimizer feature that ensures maximum torque per ampere, reducing energy drawn from the supply. The built-in energy efficiency calculators help you to analyze and optimize processes. We can help you to investigate the energy saving potential of selected applications with our six-step energy appraisal. Our services expand through the life cycle of the drive and help you maintain energy efficiency from installation and commissioning to drive replacement.





Business all-compatible

The new all-compatible drives are not just equipment but part of your business strategy. Providing better control over your processes, the new drives equal lower energy consumption, improved productivity, flexibility and ease of use. In addition to drives we offer a wide range of products and services to support your business. With offices in over 90 countries and a global technical partner network, we are in a good position to offer technical advice and local support, worldwide.

How to select a drive

Many of the features for the ACS880 single drives are built-in as standard, making selection easy. A wide range of options are available to optimize the drive for different requirements. To choose the right drive for your application, please refer to the rating tables or use ABB's DriveSize dimensioning tool.

The selected drive has a unique type designation, which identifies the drive by construction, power and voltage range. The options are added to the type designation with a "plus" code. Build up your own ordering code using the type designation key or contact your local ABB drives sales office and let them know your needs/requirements.

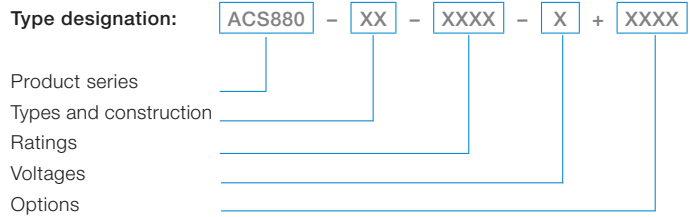

Technical data

Mains connection	
Voltage and power range	3-phase, U_{N2} = 208 to 240 V, +10/-15% (-01) 3-phase, U_{N5} = 380 to 500 V, +10/-15% (-01), ±10% (-07) 3-phase, U_{N7} = 525 to 690 V, +10/-15% (-01), ±10% (-07) 0.75 to 350 hp (0.55 to 250 kW) (-01) 60 to 1700 hp (45 to 1300 kW) (-07)
Frequency	50/60 Hz ±5%
Power factor	$\cos\phi_1$ = 0.98 (fundamental) $\cos\phi$ = 0.93 to 0.95 (total)
Efficiency (at nominal power)	98%
Motor connection	
Voltage	3-phase output voltage 0 to $U_{N2}/U_{N3}/U_{N5}/U_{N7}$
Frequency	0 to ±500 Hz ^{1) 2)}
Motor control	Direct torque control (DTC)
Torque control:	Torque step rise time: Open loop <5 ms with nominal torque Closed loop <5 ms with nominal torque Non-linearity: Open loop ± 4% with nominal torque Closed loop ± 3% with nominal torque
Speed control:	Static accuracy: Open loop 10% of motor slip Closed loop 0.01% of nominal speed Dynamic accuracy: Open loop 0.3 to 0.4% seconds with 100% torque step Closed loop 0.1 to 0.2% seconds with 100% torque step
Product compliance	
<ul style="list-style-type: none"> - CE - Low Voltage Directive 2006/95/EC - Machinery Directive 2006/42/EC - EMC Directive 2004/108/EC - Quality assurance system ISO 9001 and Environmental system ISO 14001 - RoHS - UL ³⁾, EAC/GOST R ⁷⁾, cUL 508A or cUL 508C ³⁾ and CSA C22.2 NO.14-10 ⁸⁾, C-Tick - Functional safety: STO TÜV Nord certificate ⁴⁾ - ATEX-certified Safe Disconnection Function, Ex II (2) GD (for -01) - Marine type approvals for -01 ⁶⁾ 	

EMC according to EN 61800-3 (2004)
Categories C3 and C2 with internal option

Environmental limits	
Ambient temperature	Transport -40 to +70 °C Storage -40 to +70 °C Operation (air-cooled) -15 to +55 °C, no frost allowed (-01) 0 to +50 °C, no frost allowed (-07) +40 to 55 °C with derating (-01) ⁵⁾ +40 to 50 °C with derating of 1%/1 °C (-07)
Cooling method	Air-cooled Dry clean air
Altitude	0 to 1,000 m Without derating 1,000 to 4,000 m With derating of 1%/100 m
Relative humidity	5 to 95%, no condensation allowed
Degree of protection	IP21 Standard (-01) IP22 Standard (-07) IP42, IP54 Option (-07)
Paint color	RAL 9017/9002 (-01), RAL 9017/7035 (-07)
Contamination levels	No conductive dust allowed
Storage	IEC 60721-3-1, Class 1C2 (chemical gases), Class 1S2 (solid particles)
Transportation	IEC 60721-3-2, Class 2C2 (chemical gases), Class 2S2 (solid particles)
Operation	IEC 60721-3-3, Class 3C2 (chemical gases), Class 3S2 (solid particles)
Functional safety	Standard Safe torque off (STO according EN/IEC 61800-5-2) IEC 61508 ed2: SIL 3, IEC 61511: SIL 3, EN/IEC 62061: SIL CL 3, EN ISO 13849-1: PL e With internal safety option Safe stop 1 (SS1), safely-limited speed (SLS), safe stop emergency (SSE), safe brake control (SBC) and safe maximum speed (SMS) EN/IEC 61800-5-2, EN/IEC 61508 ed2: SIL 3, IEC 61511: SIL 3, EN/IEC 62061: SIL CL 3, EN ISO 13849-1: PL e TÜV Nord certified ⁴⁾

C = Chemically active substances
S = Mechanically active substances
¹⁾ For higher operational output frequencies please contact your local ABB office
²⁾ Operation above 150 Hz might require type specific derating, please contact your local ABB office
³⁾ Pending; -07 (R10 to R11), -01 (R8 to R9, IP55)
⁴⁾ Please check availability for -07
⁵⁾ Please see pages 12 to 13 for further details
⁶⁾ Pending
⁷⁾ EAC will replace GOST R
⁸⁾ CSA pending -01 (230 V R4 to R8)

Wall-mounted single drives, ACS880-01

Our wall-mounted drives are designed on ABB's common drives architecture. They are customized to the precise needs of industries such as oil and gas, mining, metals, chemicals, cement, power plants, material handling, pulp and paper, sawmills and marine. They are designed to control a wide range of applications including cranes, extruders, winches, winders, conveyors, mixers, compressors, pumps and fans. The drive comes in nine different frame sizes (R1 to R9) for easy installment and commissioning.

At the heart of the drive is direct torque control (DTC), ABB's premier motor control technology. The extensive range of options include EMC filters, encoders, resolvers, du/dt filters, sine filters and chokes, as well as application specific software. Built-in safety features reduce the need for external safety components.

Multiple drives can be daisy-chained for synchronized drive-to-drive communication. The drives offering includes enclosure class IP21 for industrial environments.

ABB provides an extensive selection of support documentation for planning including dimension drawings in different formats, EPLAN P8 macros and line apparatus selection tool for selecting external components on the line side and motor side of the drive.

Main features

- Enclosure class IP21
- Compact design for easy installation, commissioning and maintenance
- Integrated safety including safe torque off (STO) as standard and the optional safety functions module, (TÜV Nord certified)
- Supports various motor types including synchronous reluctance motors
- Intuitive control panel with USB connection
- Removable memory unit for easy maintenance
- Drive composer PC tool for commissioning and configuration
- Primary control program - common software used throughout the ACS880 drive series
- Control unit supporting a wide range of fieldbuses, feedback devices and input/output options
- Coated boards as standard
- Controllable cooling fan
- Incoming air temperature measurement for protecting the drive from different temperature related failure mechanisms
- Built-in braking chopper, option for frame sizes R5 to R9
- EMC filter option
- du/dt filter option for motor protection
- Built-in choke
- ACS880-01 single drives are optimized for easy and cost efficient cabinet installation



ACS880-01, frame sizes R1 to R9, IP21

Ratings, types and voltages

Wall-mounted drives, ACS880-01

$U_N = 240\text{ V}$ (range 208 to 240 V). Power ratings are valid at nominal voltage 230 V (0.75 to 100 hp).

Nominal ratings	Light-overload use			Heavy-duty use			Noise level	Heat dissipation	Air flow		Type designation	Frame size
	I_{\max} A	I_{Ld} A	P_{Ld} hp	P_{Ld} kW	I_{Hd} A	P_{Hd} hp			P_{Hd} kW	dBA		
6.3	4.4	1	1	3.7	0.75	0.55	46	73	26	44	ACS880-01-04A6-2	R1
7.8	6.3	1.5	1.1	4.6	1	1	46	94	26	44	ACS880-01-06A6-2	R1
11.2	7.1	2	2	6.6	1.5	1.1	46	122	26	44	ACS880-01-07A5-2	R1
12.8	10.1	3	2	7.5	2	2	46	172	26	44	ACS880-01-10A6-2	R1
18	16	5	4	10.6	3	2	51	232	52	88	ACS880-01-16A8-2	R2
28.6	23.1	7.5	5.5	16.8	5	4	51	337	52	88	ACS880-01-24A3-2	R2
41	29.3	10	8	24.3	7.5	5.5	57	457	79	134	ACS880-01-031A-2	R3
64	44	15	11	38	10	8	62	500	79	134	ACS880-01-046A-2	R4
76	58	20	15	45	15	11	62	630	165	280	ACS880-01-061A-2	R4
104	71	25	19	61	20	15	62	680	165	280	ACS880-01-075A-2	R5
122	83	30	22	72	25	19	62	730	165	280	ACS880-01-087A-2	R5
148	109	40	30	87	30	22	67	840	256	435	ACS880-01-115A-2	R6
178	138	50	37	105	40	30	67	940	256	435	ACS880-01-145A-2	R6
247	162	60	45	145	50	37	67	1260	265	450	ACS880-01-170A-2	R7
287	196	75	55	169	60	45	67	1500	265	450	ACS880-01-206A-2	R7
362	260	100	75	213	75	55	65	2100	324	550	ACS880-01-274A-2	R8

$U_N = 500\text{ V}$ (range 380 to 500 V). Power ratings are valid at nominal voltage 480 V (0.75 to 350 hp).

Nominal ratings	Light-overload use			Heavy-duty use			Noise level	Heat dissipation	Air flow		Type designation	Frame size
	I_{\max} A	I_{Ld} A	P_{Ld} hp	P_{Ld} kW	I_{Hd} A	P_{Hd} hp			P_{Hd} kW	dBA		
3.1	2.1	1	0.75	1.7	0.75	0.55	46	30	26	44	ACS880-01-02A1-5	R1
4.1	3	1.5	1.1	2.1	1	0.75	46	40	26	44	ACS880-01-03A0-5	R1
5.6	3.4	2	1.5	3	1.5	1.1	46	52	26	44	ACS880-01-03A4-5	R1
6.8	4.8	3	2.2	3.4	2	1.5	46	73	26	44	ACS880-01-04A8-5	R1
12.2	7.6	5	4	5.2	3	3	46	122	26	44	ACS880-01-07A6-5	R1
16	11	7.5	5.5	7.6	5	4	46	172	26	44	ACS880-01-11A0-5	R1
21	14	10	7.5	11	7.5	5.5	51	232	52	88	ACS880-01-014A-5	R2
29	21	15	11	14	10	7.5	51	337	52	88	ACS880-01-021A-5	R2
42	27	20	15	21	15	11	57	457	79	134	ACS880-01-027A-5	R3
54	34	25	19	27	20	15	57	562	79	134	ACS880-01-034A-5	R3
64	40	30	22	34	25	18.5	62	667	79	280	ACS880-01-040A-5	R4
76	52	40	30	40	30	22	62	907	165	280	ACS880-01-052A-5	R4
104	65	50	37	52	40	30	62	1117	165	280	ACS880-01-065A-5	R5
122	77	60	45	65	50	37	62	1120	165	280	ACS880-01-077A-5	R5
148	96	75	55	77	60	45	67	1295	256	435	ACS880-01-096A-5	R6
178	124	100	75	96	75	55	67	1440	256	435	ACS880-01-124A-5	R6
247	156	125	90	124	100	75	67	1940	265	450	ACS880-01-156A-5	R7
287	180	150	110	156	125	90	67	2310	265	450	ACS880-01-180A-5	R7
350	240	200	132	180	150	110	65	3300	324	550	ACS880-01-240A-5	R8
498	302	250	187.5	240	200	132	68	4200	677	1150	ACS880-01-302A-5	R9
542	361	300	200	302	250	187.5	68	4800	677	1150	ACS880-01-361A-5	R9
542	414 ¹⁾	350	250	361 ²⁾	300	200	68	6000	677	1150	ACS880-01-414A-5	R9

¹⁾ At an ambient temperature of 30°C (86°F), 393A at 40°C (104°F)

²⁾ 125% overload for 1 minute every 5 minutes

Ratings, types and voltages

Wall-mounted drives, ACS880-01

$U_N = 600$ V (range 525 to 690 V). Power ratings are valid at nominal voltage 575 V (5 to 250 hp).

Nominal ratings	Light-overload use			Heavy-duty use			Noise level	Heat dissipation	Air flow		Type designation	Frame size
	I_{\max} A	I_{Ld} A	P_{Ld} hp	P_{Ld} kW	I_{Hd} A	P_{Hd} hp			P_{Hd} kW	dBA		
12.2	9	7.5	5.5	6.1	5	4	62	217	165	280	ACS880-01-07A3-7	R5
18	11	10	7.5	9	7.5	5.5	62	284	165	280	ACS880-01-09A8-7	R5
22	17	15	11	11	10	7.5	62	399	165	280	ACS880-01-14A2-7	R5
29	22	20	15	17	15	11	62	490	165	280	ACS880-01-018A-7	R5
44	27	25	18.5	22	20	15	62	578	165	280	ACS880-01-022A-7	R5
54	32	30	22	27	25	18.5	62	660	165	280	ACS880-01-026A-7	R5
64	41	40	30	32	30	22	62	864	165	280	ACS880-01-035A-7	R5
70	52	50	37	41	40	30	62	998	165	280	ACS880-01-042A-7	R5
71	52	50	37	41	40	30	62	1120	165	280	ACS880-01-049A-7	R5
104	62	60	45	52	50	37	67	1295	256	435	ACS880-01-061A-7	R6
124	77	75	55	62	60	45	67	1440	256	435	ACS880-01-084A-7	R6
168	99	100	75	77	75	55	67	1940	265	450	ACS880-01-098A-7	R7
198	125	125	90	99	100	75	67	2310	265	450	ACS880-01-119A-7	R7
250	144	150	110	125	125	90	65	3300	324	550	ACS880-01-142A-7	R8
274	180 ⁴⁾	200	132	144	150	110	65	3900	324	550	ACS880-01-174A-7	R8
384	242	250	160	192	200	132	68	4200	677	1150	ACS880-01-210A-7	R9
411	271	250 ⁵⁾	200	242 ³⁾	250	160	68	4800	677	1150	ACS880-01-271A-7	R9

³⁾ 130% overload for 1 minute every 5 minutes

⁴⁾ Drive is capable of 192 amps with no overload

⁵⁾ Power rating is per NEC table 42.1. Drive can be used for a 300 hp 4 pole motor meeting EPA efficiency standards (NEMA MG 1, table 12-11) if motor full load current does not exceed 271 amps

Frame size	Height 1		Height 2		Width		Depth		Weight	
	UL type 1 (in)	IP21 (mm)	UL type 1 (in)	IP21 (mm)	UL type 1 (in)	IP21 (mm)	UL type 1 (in)	IP21 (mm)	UL type 1 (lb)	IP21 (mm)
R1	16	405	14.6	370	6.1	155	8.9	226	13.2	6
R2	16	405	14.6	370	6.1	155	9.8	249	17.6	8
R3	18.5	471	16.5	420	6.8	172	10.3	261	22	10
R4	22.6	573	19.3	490	8.0	203	10.8	274	40.8	18.5
R5	28.7	730	23.5	596	8.0	203	10.8	274	50.7	23
R6	28.6	726	22.4	569	9.9	251	14.1	357	99.2	45
R7	34.6	880	23.6	600	11.2	284	14.4	365	121.3	55
R8	37.9	963	26.8	681	11.8	300	15.2	386	154.3	70
R9	37.6	955	26.7	680	15.0	380	16.3	413	216	98

H1 = Height with cable entry box

H2 = Height without cable entry box

Width and depth with cable entry box

Nominal ratings

I_{\max} | Maximum output current. Available for 10 seconds at start, then as long as allowed by drive temperature.

Light-overload use

I_{Ld} | Continuous current allowing 110% I_{Ld} for 1 min/5 min at 40 °C.

P_{Ld} | Typical motor power in light-overload use.

Heavy-duty use

I_{Hd} | Continuous current allowing 150% I_{Hd} for 1 min/5 min at 40 °C.

P_{Hd} | Typical motor power in heavy-duty use.

The ratings apply at 40 °C ambient temperature. At higher temperatures (up to 55 °C) the derating is 1%/1 °C.

Cabinet-built single drives, ACS880-07

Our cabinet-built single drives are built to order, meeting customer needs despite any technical challenges. Designed on ABB's common drives architecture, this compact drive comes in different sizes for easy assembly and commissioning.

These single drives are customized to the precise needs of industries such as oil and gas, mining, metals, chemicals, cement, power plants, material handling, pulp and paper, woodworking and marine. Typical applications include cranes, extruders, winches, conveyors, mixers, compressors, pumps and fans. The drive configuration contains a rectifier, DC link, inverter, fuses and a main switch, all built into a compact cabinet. The features and options include extended inputs and outputs, fieldbus options, du/dt filtering, EMC filtering and a brake resistor.

Induction motors, synchronous motors and induction servo motors are all supported as standard without the need for additional software. The drive can control the motors in either open loop or closed loop, through its high precision motor control platform, direct torque control (DTC). Built-in safety features reduce the need for external safety components.

Main features

- Compact design for easy cabinet assembly and maintenance
- Main switch and fuses
- Cabling solutions include bottom and top entry and exit
- Enclosure classes IP22, IP42 and IP54 for different environments, with option for air intake through bottom of the cabinet and channeled air outlet on the top of the cabinet
- Integrated safety including safe torque off (STO) as standard and the optional safety functions module, (TÜV Nord certificate)
- Supports various motor types including synchronous reluctance motors
- Drive composer PC tool for commissioning and configuration
- Intuitive and easy to operate control panel with USB connection
- Device panel for optional switches and pilot light
- Primary control program – common software used throughout the ACS880 drive series
- Control unit supporting a wide range of fieldbuses, feedback devices and input/output options
- Removable memory unit for easy maintenance
- Coated boards as standard
- Extensive, programmable digital and analog inputs and outputs
- Long lifetime capacitors
- Cooling fans with speed control or on-off control
- Braking option inside the module or cabinet
- EMC filter option
- du/dt and common mode filter options for motor protection
- Cabinet light and heater option



ACS880-07, frame sizes R6 to R8 and R11, IP22



ACS880-07, frame size 1xD8T+2xR8i, IP22

Ratings, types and voltages

Cabinet-built drives, ACS880-07

$U_N = 500$ V (range 380 to 500 V). The power ratings are valid at nominal voltage 480 V (60 to 1.700 hp)

Nominal ratings	Light-overload use			Heavy-duty use			Noise level	Heat dissipation	Air flow	Type designation	Frame size
	I_{max} A	I_{Ld} A	P_{Ld} hp kW	I_{Hd} A	P_{Hd} hp kW	P_{Hd} kW	dBA	W	m ³ /h		

6-pulse diode

148	96	75	55	77	60	45	67	1795	1750	ACS880-07-0096A-5	R6
178	124	100	75	96	75	55	67	1940	1750	ACS880-07-0124A-5	R6
247	156	125	90	124	100	75	67	2440	1750	ACS880-07-0156A-5	R7
287	180	150	110	156	125	90	67	2810	1750	ACS880-07-0180A-5	R7
350	240	200	132	180	150	110	65	3800	1750	ACS880-07-0240A-5	R8
498	302	250	200	260	200	132	68	4700	1150	ACS880-07-0302A-5	R9
542	361	300	200	302	250	200	68	5300	1150	ACS880-07-0361A-5	R9
542	414 ¹⁾	350	250	361 ²⁾	300	200	68	6500	1150	ACS880-07-0414A-5	R9
560	483	400	315	361	300	250	72	6102	2950	ACS880-07-0503A-5	R10
730	573	450	400	414	350	250	72	6909	2950	ACS880-07-0583A-5	R10
730	623	500	450	477	400	315	72	8622	2950	ACS880-07-0635A-5	R10
850	705	600	500	566	450	400	72	9264	2950	ACS880-07-0715A-5	R11
1020	807	700	560	625	500	450	71	10362	2950	ACS880-07-0820A-5	R11
1391	1027	900	710	800	700	560	73	18000	4290	ACS880-07-1070A-5	D8T+2xR8i
1716	1267	1100	900	987	850	710	74	22000	5720	ACS880-07-1320A-5	2xD8T+2xR8i
2060	1517	1350	1000	1182	1000	800	74	27000	5720	ACS880-07-1580A-5	2xD8T+2xR8i
2574	1901	1700	1300	1481	1300	1000	75	36000	7150	ACS880-07-1980A-5	2xD8T+3xR8i

¹⁾ At an ambient temperature of 30 °C (86 °F), 393 A at 40 °C (104 °F)

²⁾ 125% overload for 1 minute every 5 minutes

Frame size	Height		Height		Width		Depth		Weight	
	UL type 1 (in)	IP22/42 (mm)	UL type 12 (in)	IP54 (mm)	UL type 1/12 (in)	IP22/42/54 (mm)	UL type 1/12 (in)	IP22/42/54 (mm)	UL type 1/12 (lb)	IP22/42/54 (kg)
R6	84.5	2145	91.2	2315	16.9	430 ^{1) 2)}	26.5	673	530	240
R7	84.5	2145	91.2	2315	16.9	430 ^{1) 2)}	26.5	673	550	250
R8	84.5	2145	91.2	2315	16.9	430 ^{1) 2)}	26.5	673	585	265
R9	84.5	2145	91.2	2315	32.7	830	27.5	698	825	375
R10	84.5	2145	91.2	2315	32.7	830 ^{1) 3)}	27.5	698	1170	530
R11	84.5	2145	91.2	2315	32.7	830 ^{1) 3)}	27.5	698	1280	580
D8T+2xR8i	84.5	2145	91.2	2315	83.9	2130 ^{1) 5) 6)}	27.5	698	1960	890
2xD8T+2xR8i	84.5	2145	91.2	2315	99.6	2530 ^{4) 5) 6)}	27.5	698	2640	1200
2xD8T+3xR8i	84.5	2145	91.2	2315	111.4	2830 ^{4) 5) 6)}	27.5	698	2970	1350

¹⁾ Add 200 mm (7.9 in) if equipped with 1st environment (C2) EMC/RFI filter

²⁾ MCCB (F289) option requires 830 mm (32.7 in) cabinet

³⁾ Add 300 mm (11.8 in) if equipped with braking chopper. The number of brake choppers depends on required braking power.

⁴⁾ Add 200 mm (7.9 in) if top entry

⁵⁾ Add 400 mm (15.7 in) if equipped with braking chopper. The number of brake choppers depends on required braking power.

⁶⁾ Includes common motor terminal cabinet

Nominal ratings

I_{max} Maximum output current. Available for 10 seconds at start, then as long as allowed by drive temperature.

Light-overload use

I_{Ld} Continuous current allowing 110% I_{Ld} for 1 min/5 min at 40 °C.

P_{Ld} Typical motor power in light-overload use.

Heavy-duty use

I_{Hd} Continuous current allowing 150% I_{Hd} for 1 min/5 min at 40 °C.

P_{Hd} Typical motor power in heavy-duty use.

The ratings apply at 40 °C ambient temperature. At higher temperatures (up to 50 °C) the derating is 1%/1 °C.

Operation above 150 Hz might require type specific derating.

Standard interface and extensions for comprehensive connectivity

The ACS880 single drives offers a wide range of standard interfaces. In addition the drive has three option slots that can be used for extensions including fieldbus adapter modules,

input/output extension modules, feedback modules and a safety functions module.

Control connections	Description
2 analog inputs (XAI)	Current input: -20 to 20 mA, R_{in} : 100 ohm Voltage input: -10 to 10 V, $R_{in} > 200$ kohm Resolution: 11 bit + sign bit
2 analog outputs (XAO)	0 to 20 mA, $R_{load} < 500$ ohm Frequency range: 0 to 300 Hz Resolution: 11 bit + sign bit
6 digital inputs (XDI)	Input type: NPN/PNP (DI1 to DI5), NPN (DI6) DI6 (XDI:6) can alternatively be used as an input for a PTC thermistor.
Digital input interlock (DIIL)	Input type: NPN/PNP
2 digital inputs/outputs (XDIO)	As input: 24 V logic levels: "0" < 5 V, "1" > 15 V R_{in} : 2.0 kohm Filtering: 0.25 ms As output: Total output current from 24 V DC is limited to 200 mA Can be set as pulse train input and output
3 relay outputs (XRO1, XRO2, XRO3)	250 V AC/30 V DC, 2 A
Safe torque off (XSTO)	For the drive to start, both connections must be closed
Drive-to-drive link (XD2D)	Physical layer: EIA-485
Built-in Modbus	EIA-485
Assistant control panel/ PC tool connection	Connector: RJ-45



Control unit ZCU

Example of a typical single drives input/output connection diagram. Variations maybe possible (please see HW manual for more information).

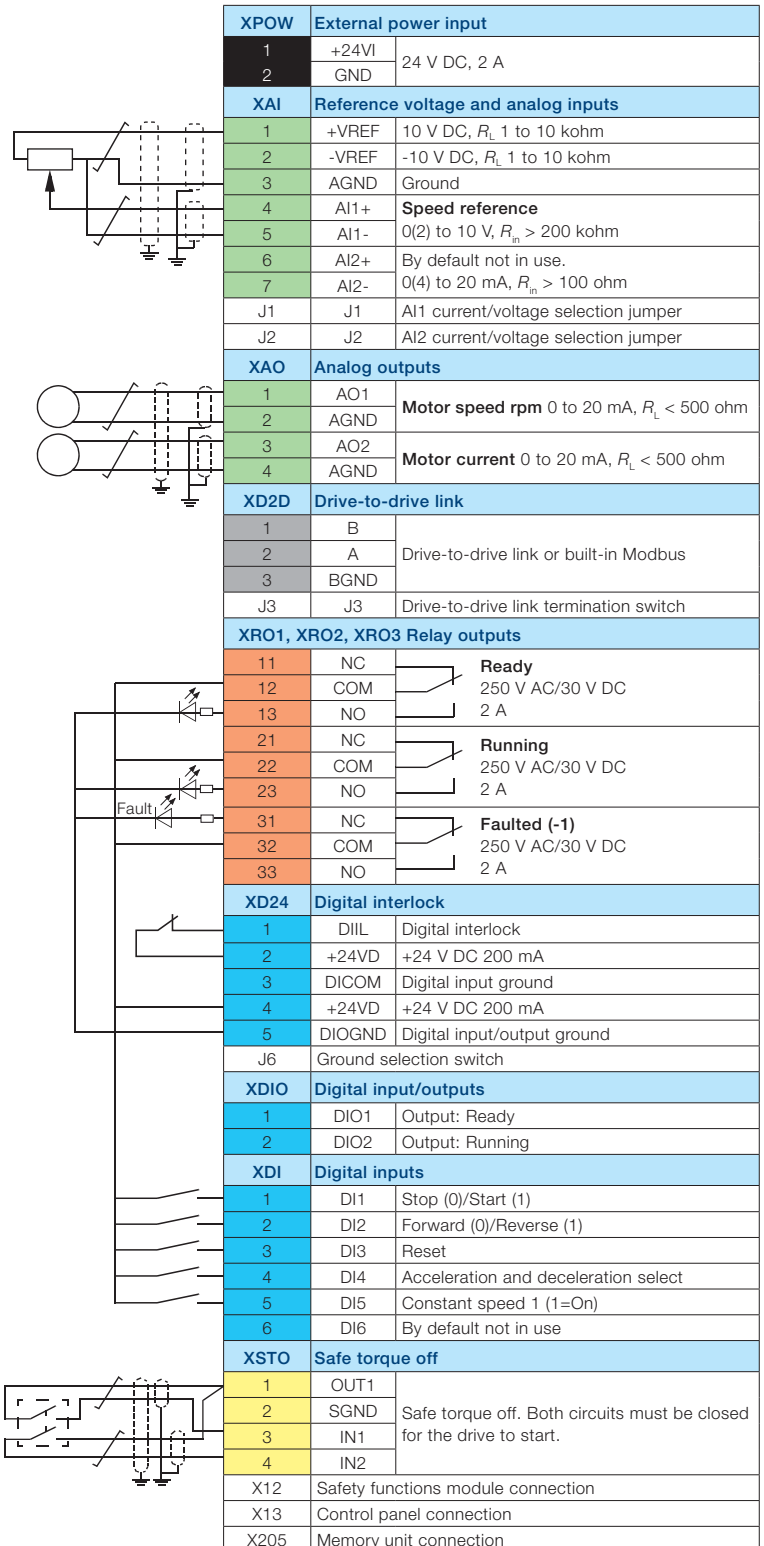

Standard software for scalable control and functionality

The same software, the primary control program, is used across the whole ACS880 series. Features such as built-in pre-programmed application macros save time during configuration and drive commissioning. The application macros help set parameters for various functions including:

- Basic setup for input/output control and fieldbus control
- Hand/auto control for local and remote operation
- PID control for closed loop processes
- Sequential control for repetitive cycles
- Torque control
- Four user sets, for saving multiple drive configurations

Direct torque control (DTC)

The drives are equipped with direct torque control (DTC), ABB's signature motor control platform which supports motors such as induction motors, permanent magnet synchronous motors and servo motors and the new synchronous reluctance motor. DTC helps control the motor from standstill to maximum torque and speed without the necessity of encoders or position sensors. DTC allows high overloadability, gives high starting torque and reduces stress on mechanics.

Energy efficiency information

The drives come with built-in energy efficiency information that helps the user fine-tune processes to ensure optimum energy use. The energy optimizer mode ensures the maximum torque per ampere, reducing energy drawn from the supply. The load profile feature collects drive values with three loggers: two amplitude loggers and one peak value logger. Calculators provide essential energy efficiency information: used and saved electrical energy, CO₂ reduction and money saved.

Additional software features include:

- Access levels
- Adaptive programming
- Automatic reset
- Automatic start
- Constant speeds
- Critical speeds and frequencies
- DC hold
- DC magnetizing
- Diagnostics
- Drive-to-drive link for master-follower control
- Flux braking
- Jogging
- Maintenance timer and counters
- Mechanical brake control
- Motor potentiometer
- Output phase order selection, switches rotation direction of the motor
- Oscillation damping
- Power loss ride-through
- Process PID control with trim function
- Programmable and pre-programmed protection functions
- Programmable inputs and outputs
- Scalar control with IR compensation
- Speed controller with auto tuning
- Startup assistants
- User adjustable load supervision/limitation
- User selectable acceleration and deceleration ramps
- Variable slope

Removable memory unit

The removable memory unit stores the software that includes user settings, parameter settings and motor data. Situated on the control unit, the memory unit can easily be removed for maintenance, update or replacement purposes. This common type of memory unit is used throughout the ACS880 series.

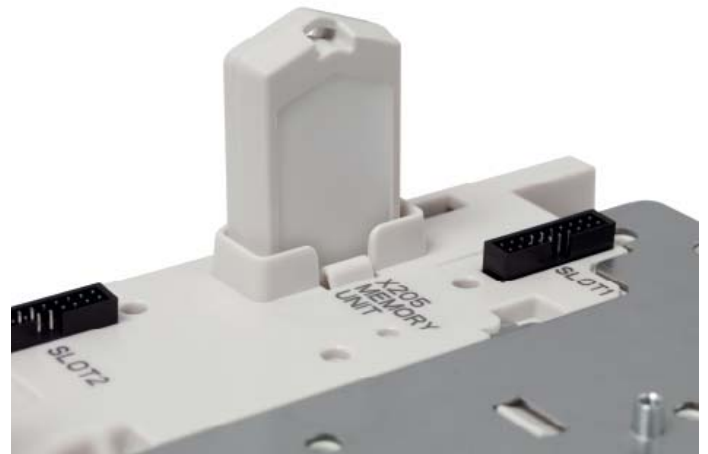

Application control programs



Our application control programs are developed by working closely with our customers over many years. This results in application programs that include the lessons learned across many customers, and that are designed to give you the flexibility to adapt the programs to your specific needs. These programs enhance application usability and lower energy consumption. They increase safe operation of the applications and reduce the need for a PLC. Other benefits include protection of machinery and optimization of application productivity. The programs also optimize time usage and lower operational costs.

The ACS880 application control programs come with adaptive programming features. This makes fine tuning of the functionality of the ready-made application control programs easy. Additionally, we understand that you may need to use different configurations in your process. That's why each of our control programs comes with the ability to configure up to four different configurations, or "user sets." The ACS880 drives offer integrated safety with safe torque off (STO) functionality as standard. The optional safety functions module, FSO-12, comes with five safety functions including safe brake control (SBC).

Control programs for cranes

This control program is dedicated for industrial, harbor, tower and marine deck cranes. It is possible to control crane movements in hoist and trolley and travel motions using the same software. The control program comes with integrated mechanical brake control to assure safe opening and closing of the mechanical disc or drum brakes. Standalone and master-follower functionality is supported along with synchro control of multimotors. The synchro control for common operation of the load functionality makes it possible to lift and lower loads, such as containers, in a smooth and balanced way during transportation. The load speed control function maximizes

the hoist speed for the given load and ensures that there is sufficient motor torque in the field weakening area. This minimizes operation time and optimizes crane capacity. Fieldbus and conventional I/O control is supported.

Control program for winder

This control program makes sure that unwinding and winding of a roll of web material, such as textile, plastic and paper is performed optimally. The control program observes the diameter of rolls and tension of the web material and makes sure that the drives controlling different parts of the winder are in sync. Based on the feedback from the dancer or tension measurement of the web, the speed or torque of the drive is adjusted properly. The result is a straightforward, cost-effective solution in web handling. Another feature is the mechanics ID run function that calculates automatically the inertia and friction of the roll. This speeds up the commissioning of the drive.

Control program for centrifuge/decanter

This control program is designed to perform practical programmable sequences for conventional centrifuges. The program optimizes the separation of solids from the liquids in centrifuges, separators or decanter centrifuges. The speed difference of the bowling and scrolling in the decanter centrifuge is controlled by the drive-to-drive functionality available in ACS880 drives.

Intuitive human-machine interface

The assistant control panel features intuitive use and easy navigation. High resolution display enables visual guidance. The panel saves on commissioning and learning time by means of different assistants, making the drive simple to set up and use.

It is possible to organize parameters in different ways and store essential parameters for different configurations for any specialized application needed. The menus and messages can be customized for specific terminology so that each application can be set up and configured to its optimum performance. This makes the drive easier to use with information that is familiar to users. With the panel's text editor, users can also add information, customize text and label the drive. Powerful backup and restore functions are supported as well as different language versions. The help key provides context sensitive

guidance. Faults or warnings can be resolved quickly since the help key provides troubleshooting instructions.

One control panel can be connected to several drives simultaneously using the panel network feature. The user can also select the drive to operate in the panel network. The PC tool can be easily connected to the drive through the USB connector on the control panel. There is also the assistant control panel mounting platform, DPMP-01 IP55 kit available for cabinet door flush mounting.



PC tool for easy startup and maintenance

The Drive composer PC tool offers fast and harmonized setup, commissioning and monitoring for the whole drives portfolio. The free version of the tool provides startup and maintenance capabilities, while the professional version provides additional features such as custom parameter windows, control diagrams of the drive's configuration and safety settings.

The Drive composer tool is connected to the drive using an Ethernet connection or through the USB connection on the assistant control panel. All drive information such as parameter loggers, faults, backups and event lists are gathered into a support diagnostics file with a single mouse click. This provides faster fault tracking, shortens downtime and minimizes operational and maintenance costs.

Drive composer pro

Drive composer pro provides basic functionality, including parameter settings, downloading and uploading files and search parameters. Advanced features such as graphical control diagrams and various displays are also available. The control diagrams save users from browsing long lists of parameters and help to set the drive's logic quickly and easily. The tool has fast monitoring capabilities of multiple signals from several drives in a PC tool network. Full backup and restore functions are also included. Safety settings can be configured with Drive composer pro.



Integrated safety simplifies configuration

Integrated safety reduces the need for external safety components, simplifying configuration and reducing installation space. The safety functionality is a built-in feature of the ACS880, with safe torque off (STO) as standard. Additional safety functions can be commissioned with the optional and compact safety functions module that includes safe stop 1 (SS1), safe stop emergency (SSE), safely-limited speed (SLS), safe brake control (SBC) and safe maximum speed (SMS). The drives' functional safety is designed according to EN/IEC 61800-5-2 and complies with the requirements of the European Union Machinery Directive 2006/42/EC.

Safe torque off as standard

Safe torque off (STO) is used to prevent unexpected startup and in stopping-related functions, enabling safe machine maintenance and operation. With safe torque off activated, the drive will not provide a rotational field. This prevents the motor from generating torque on the shaft. This function corresponds to an uncontrolled stop in accordance with stop category 0 of EN 60204-1.

The safety functions module

The easy to connect and configure safety functions module comes with a range of safety functions and a self-diagnostic function that meets current safety requirements and standards, in one compact module. Compared to using external safety components, the safety functions module comes with the supported functions seamlessly integrated with the drive functionality, reducing the implementation of safety function connections and configuration. Installing a safety functions module results in less needs for cabling and provides a cost-effective solution packed into a single safety functions module to ensure safe operation. Commissioning and configuration of the safety functions is done with the Drive composer pro PC tool. The drive and safety functions module are easy to connect to a safety PLC using PROFIsafe over profinet fieldbus adapter module (FENA-11).

The safety functions module supports the following safety functions (which achieve up to SIL 3 or PL e safety level (Cat. 3)):

- **Safe stop 1 (SS1)** brings the machine to a stop (STO) using a monitored deceleration ramp. It is typically used in applications where the machinery motion needs to be brought to a stop (stop category 1) in a controlled way before switching over to the no-torque state.
- **Safe stop emergency (SSE)** can be configured to, upon request, either activate STO instantly (category 0 stop), or first initiate motor deceleration and then, once the motor has stopped, activate the STO (category 1 stop).
- **Safe brake control (SBC)** provides a safe output for controlling the motor's external (mechanical) brakes, together with STO.
- **Safely-limited speed (SLS)** ensures that the specified speed limit of the motor is not exceeded. This allows machine interaction to be performed at slow speed without stopping the drive. Safety functions modules come with four individual SLS settings for speed monitoring.
- **Safe maximum speed (SMS)** monitors that the speed of the motor does not exceed the configured speed limit.

Safety functions module

Option	Ordering code
Safety functions module	+Q973



ACS880 drive with safety functions module



Safety functions module



ACS880 cabinet-built drive with safety functions module

Drive application programming with CODESYS

Automation Builder, ABB's new software suite for automation engineering, makes programming of industry devices such as drives, PLC's, robots and human machine interfaces (HMI) easy using one Integrated engineering suite. The Automation Builder is used both for engineering individual industry devices and for putting together entire automation projects. It is based on CODESYS, a widely used software environment that fulfills many different requirements of industrial automation projects, according to the IEC standard 61131-3. As a single tool, the Automation Builder reduces time typically needed for system configuration and programming. It also reduces the need for installing and maintaining separate programs simultaneously. Automation Builder enables the possibility to do online diagnostic checking of multiple tasks performed by different industrial devices such as ACS880 drives.

Drive application programming

Automation Builder makes it possible for system integrators and machine builders to integrate their desired functionality and know-how directly into ACS880 drives. This is possible as ACS880 drives come with CODESYS programming capability embedded inside the drive. Designing a CODESYS-based application program in the drive makes the end user application run more efficiently, even without a separate programmable controller. It also brings higher end-product quality and requires less need for installation space and wiring.

Automation Builder lets you extend the standard functionality of parameter functions for ACS880 drives. This makes the ACS880 drives very flexible to meet exact requirements set for end user applications. The library management functionality in Automation Builder shortens engineering time as reuse of existing program code is possible. Additional features include the ability to select and use one of five different programming languages, effective program debugging and user password protection.

Integrated engineering suite for operating several industry components together

Using the Drive manager tool embedded in Automation Builder together with ABB's AC500 PLC gives the user online connection to all drives in a fieldbus network. This speeds up commissioning and makes diagnostic of the entire automation system easy. Automation Builder saves all the configuration data of industry devices (including drive parameter settings) and program code to the same project archive. This makes engineering work more consistent and manageable.

The drive application programming license should be ordered together with the drive.

Drive application programmability

Option	Option code
License key ¹⁾	+N8010

¹⁾ The Automation Builder tools must be ordered separately.
For further information please contact your local ABB



Automation Builder

One engineering tool to control all industry devices
System configuration and diagnostic
IEC programming
Common project data handling

Flexible connectivity to automation networks

Our fieldbus adapter modules enable communication between drives, systems, devices and software. Our industrial drives are compatible with a wide range of fieldbus protocols.

The plug-in fieldbus adapter module can easily be mounted inside the drive. Other benefits include reduced wiring costs when compared with traditional input/output connections. Fieldbus systems are also less complex than conventional systems, resulting in less overall maintenance.

Multiple fieldbus connections for flexible control

ACS880 supports two fieldbus connections simultaneously. The user has flexibility of choice for control modes by being able to select one protocol for control and one for monitoring.

Drive monitoring

A set of drive parameters and/or actual signals, such as torque, speed, current, etc., can be selected for cyclic data transfer, providing fast data access.

Drive diagnostics

Accurate and reliable diagnostic information can be obtained through the alarm, limit and fault words.

Drive parameter handling

The Ethernet fieldbus adapter module allows users to build an Ethernet network for drive monitoring and diagnostic and parameter handling purposes.

Cabling

Substituting the large amount of conventional drive control cabling and wiring with a single cable reduces costs and increases system reliability and flexibility.

Design

The use of fieldbus control reduces engineering time at installation due to the modular structure of the hardware and software and the simplicity of the connections to the drives.

Commissioning and assembly

The modular machine configuration allows pre-commissioning of single machine sections and provides easy and fast assembly of the complete installation.

Universal communication with ABB fieldbus adapters

The ACS880 supports the following fieldbus protocols:

Fieldbus adapter modules

Option	Option code	Fieldbus protocol
FPBA-01	+K454	PROFIBUS DP, DPV0/DPV1
FCAN-01	+K457	CANopen®
FDNA-01	+K451	DeviceNet™
FENA-11	+K473	1 port EtherNet/IP™, Modbus TCP, PROFINET IO
FECA-01	+K469	EtherCAT®
FSCA-01	+K458	Modbus RTU
FEPL-02	+K470	PowerLink
FCNA-01	+K462	ControlNet™



ACS880 drive with fieldbus adapters and feedback interface module

Input/output extension modules for increased connectivity

Standard input and output can be extended by using optional analog and digital input/output extension modules. The modules are easily installed in the extension slots located on the control unit.

Analog and digital input/output extension modules

Option	Option code	Connections
FIO-01	+L501	4×DI/O, 2×RO
FIO-11	+L500	3×AI (mA/V), 1×AO (mA), 2×DI/O
FAIO-01	+L525	2×AI(mA/V), 2×AO(mA)

FIO-01



Speed feedback interfaces for precise process control

ACS880 drives can be connected to various feedback devices, such as HTL pulse encoder, TTL pulse encoder, absolute encoder and resolver. The optional feedback module is installed in the option slot on the drive. It is possible to use two feedback modules at the same time, either of the same type or different type.

Feedback interface modules

Option	Option code	Connections
FEN-01	+L517	2 inputs (TTL pulse encoder), 1 output
FEN-11	+L518	2 inputs (SinCos absolute, TTL pulse encoder), 1 output
FEN-21	+L516	2 inputs (Resolver, TTL pulse encoder), 1 output
FEN-31	+L502	1 input (HTL pulse encoder), 1 output

FEN-21



DDCS communication option modules

The FDCO-0X optical DDCS communication options are add-on modules on the ACS880 industrial drives control board. The modules include connectors for two fiber optic DDCS channels. The FDCO-0X modules make it possible to perform master-follower and AC800 M communication.

Option	Option code	Connections
FDCO-01	+L503	Optical DDCS (10 Mbd/10 Mbd)
FDCO-02	+L508	Optical DDCS (5 Mbd/10 Mbd)

EMC – electromagnetic compatibility

Each ACS880 model can be equipped with a built-in filter to reduce high frequency emissions.

EMC standards

The EMC product standard (EN 61800-3 (2004)) covers the specific EMC requirements stated for drives (tested with motor and cable) within the EU. EMC standards such as EN 55011 or EN 61000-6-3/4 are applicable to industrial and domestic equipment and systems including components inside the drive. Drive units complying with the requirements of EN 61800-3 are compliant with comparable categories in EN 55011 and EN 61000-6-3/4, but not necessarily vice versa. EN 55011 and EN 61000-6-3/4 do not specify cable length or require a motor to be connected as a load. The emission limits are comparable to EMC standards according to the table below.

1st environment versus 2nd environment

1st environment includes domestic premises. It also includes establishments directly connected without an intermediate transformer to a low voltage power supply network that supplies buildings used for domestic purposes.

2nd environment includes all establishments other than those directly connected to a low voltage power supply network that supplies buildings used for domestic purposes.

EMC standards

EMC according to EN 61800-3 (2004) product standard	EN 61800-3 product standard	EN 55011, product family standard for industrial, scientific and medical (ISM) equipment	EN 61000-6-4, generic emission standard for industrial environments	EN 61000-6-3, generic emission standard for residential, commercial and light-industrial environment
1 st environment, unrestricted distribution	Category C1	Group 1, Class B	Not applicable	Applicable
1 st environment, restricted distribution	Category C2	Group 1, Class A	Applicable	Not applicable
2 nd environment, unrestricted distribution	Category C3	Group 2, Class A	Not applicable	Not applicable
2 nd environment, restricted distribution	Category C4	Not applicable	Not applicable	Not applicable

Selecting an EMC filter

The following table gives the correct filter selection.

Type	Voltage	Frame sizes	1 st environment, restricted distribution, C2, grounded network (TN) Option code	2 nd environment, C3, grounded network (TN) Option code	2 nd environment, C3, ungrounded network (IT) Option code	2 nd environment, C3, grounded/ungrounded network (TN/IT) Option code
ACS880-01	380 to 500 V	R1 to R9	+E202	+E200	+E201 (R6 to R9 frame size)	–
ACS880-01	690 V	R5 to R9	–	+E200 (R5 to R9 frame size)	+E201 (R7 to R9 frame size)	–
ACS880-07	380 to 690 V	R6 to R11	+E202 (not for 690 V)	+E200	+E201	+E210 (R10 to R11)
ACS880-07	380 to 690 V	n×R8i	+E202 (not for 690 V only for 0990A, 1070A and 1140A)	–	–	As standard

Brake options

Brake chopper

The brake chopper is built-in as standard for the ACS880-01 frame sizes R1 to R4. For other frames, a brake chopper is a selectable internal option. Braking control is integrated into the ACS880 single drives. It not only controls braking, but also supervises system status and detects failures such as brake resistor and resistor cable short-circuits, chopper short-circuit, and calculated resistor overtemperature.

Brake resistor

The brake resistors are separately available for ACS880-01 and built in for the cabinet-built ACS880-07. Resistors other than the standard option resistors may be used, provided that the specified resistance value is not decreased and that the heat

dissipation capacity of the resistor is sufficient for the drive application. No separate fuses in the brake circuit are required if the conditions for eg. the mains cable is protected with fuses and no mains cable/fuse overrating takes place.



Brake resistor, SACE15RE13

Brake options, ACS880-01

$U_N = 230\text{ V}$ (range 208 to 240 V)			
Brake chopper power		Type designation	Frame size
P_{brcont} [kW]	R_{min} ohm		
0.75	65	ACS880-01-04A6-2	R1
1.1	65	ACS880-01-06A6-2	R1
1.5	65	ACS880-01-07A5-2	R1
2.2	65	ACS880-01-10A6-2	R1
4	18	ACS880-01-16A8-2	R2
5.5	18	ACS880-01-24A3-2	R2
7.5	13	ACS880-01-031A-2	R3
11	12	ACS880-01-046A-2	R4
11	12	ACS880-01-061A-2	R4
18.5	6	ACS880-01-075A-2+D150	R5
22	6	ACS880-01-087A-2+D150	R5
30	3.5	ACS880-01-115A-2+D150	R6
37	3.5	ACS880-01-145A-2+D150	R6
45	2.4	ACS880-01-170A-2+D150	R7
55	2.4	ACS880-01-206A-2+D150	R7
75	1.8	ACS880-01-274A-2+D150	R8

$U_N = 500\text{ V}$ (range 380 to 500 V)			
Brake chopper power		Type designation	Frame size
P_{brcont} [kW]	R_{min} ohm		
0.75	78	ACS880-01-02A1-5	R1
1.1	78	ACS880-01-03A0-5	R1
1.5	78	ACS880-01-03A4-5	R1
2.2	78	ACS880-01-04A8-5	R1
3	78	ACS880-01-05A2-5	R1
4	78	ACS880-01-07A6-5	R1
5.5	78	ACS880-01-11A0-5	R1
7.5	39	ACS880-01-014A-5	R2
11	39	ACS880-01-021A-5	R2
15	19	ACS880-01-027A-5	R3
18.5	19	ACS880-01-034A-5	R3
22	13	ACS880-01-040A-5	R4
22	13	ACS880-01-052A-5	R4
37	8	ACS880-01-065A-5+D150	R5
45	8	ACS880-01-077A-5+D150	R5
55	5.4	ACS880-01-096A-5+D150	R6
75	5.4	ACS880-01-124A-5+D150	R6
90	3.3	ACS880-01-156A-5+D150	R7
110	3.3	ACS880-01-180A-5+D150	R7
132	2.3	ACS880-01-240A-5+D150	R8
132	2.3	ACS880-01-260A-5+D150	R8
160	2.3	ACS880-01-361A-5+D150	R9
160	2.3	ACS880-01-414A-5+D150	R9

Brake options, ACS880-01

$U_N = 690 \text{ V}$ (range 525 to 690 V)			
Brake chopper power		Type designation	Frame size
P_{brcont} [kW]	R_{min} ohm		
6	18	ACS880-01-07A3-7+D150	R5
8	18	ACS880-01-09A8-7+D150	R5
11	18	ACS880-01-14A2-7+D150	R5
17	18	ACS880-01-018A-7+D150	R5
23	18	ACS880-01-022A-7+D150	R5
28	18	ACS880-01-026A-7+D150	R5
33	18	ACS880-01-035A-7+D150	R5
45	18	ACS880-01-042A-7+D150	R5
45	18	ACS880-01-049A-7+D150	R5
55	13	ACS880-01-061A-7+D150	R6
65	13	ACS880-01-084A-7+D150	R6
90	8	ACS880-01-098A-7+D150	R7
110	8	ACS880-01-119A-7+D150	R7
132	6	ACS880-01-142A-7+D150	R8
160	6	ACS880-01-174A-7+D150	R8
200	4	ACS880-01-210A-7+D150	R9
200	4	ACS880-01-271A-7+D150	R9

Brake options, ACS880-07

$U_N = 500 \text{ V}$ (range 380 to 500 V)			
Brake chopper power		Type designation	Frame size
P_{brcont} [kW]	R_{min} ohm		
55	5.4	ACS880-07-0096A-5+D150	R6
75	5.4	ACS880-07-0124A-5+D150	R6
90	3.3	ACS880-07-0156A-5+D150	R7
110	3.3	ACS880-07-0180A-5+D150	R7
132	2.3	ACS880-07-0240A-5+D150	R8
160	2.3	ACS880-07-0302A-5+D150	R9
160	2.3	ACS880-07-0361A-5+D150	R9
160	2.3	ACS880-07-0414A-5+D150	R9
250	2	ACS880-07-0503A-5+D150	R10
315	1.3	ACS880-07-0583A-5+D150	R10
315	1.3	ACS880-07-0635A-5+D150	R10
400	0.7	ACS880-07-0715A-5+D150	R11
400	0.7	ACS880-07-0805A-5+D150	R11

du/dt filters

du/dt filtering suppresses inverter output voltage spikes and rapid voltage changes that stress motor insulation. Additionally, du/dt filtering reduces capacitive leakage currents and high frequency emission of the motor cable as well as high frequency losses and bearing currents in the motor. The need for du/dt filtering depends on the motor insulation. For information on the construction of the motor insulation, consult the manufacturer.

If the motor does not fulfil the following requirements, the lifetime of the motor might decrease. Insulated N-end (non-driven end) bearings and/or common mode filters are also required for motor bearing currents with motors bigger than 100 kW. For more information, please see the ACS880 hardware manuals.

Please see below about how to select a filter according to the motor.

Filter selection table for ACS880

Motor type	Nominal AC supply voltage	Requirements for		
		Motor insulation system	ABB du/dt and common mode filters, insulated N-end motor bearings	
			$P_N < 100$ kW and frame size < IEC 315	100 kW $\leq P_N < 350$ kW or IEC 315 \leq frame size < IEC 400
			$P_N < 134$ hp and frame size < NEMA 500	134 hp $\leq P_N < 469$ hp or NEMA 500 \leq frame size \leq NEMA 580
ABB motors				
Random-wound M2__, M3__ and M4__	$U_N \leq 500$ V	Standard	–	+ N
	500 V < $U_N \leq 600$ V	Standard	+ du/dt	+ du/dt + N
		or Reinforced	–	+ N
	600 V < $U_N \leq 690$ V (cable length ≤ 150 m)	Reinforced	+ du/dt	+ du/dt + N
600 V < $U_N \leq 690$ V (cable length > 150 m)	Reinforced	–	+ N	
Form-wound HX__ and AM__	380 V < $U_N \leq 690$ V	Standard	n/a	+ N + CMF
Old ¹⁾ form-wound HX__ and modular	380 V < $U_N \leq 690$ V	Check with the motor manufacturer	+ du/dt with voltages over 500 V + N + CMF	
Random-wound HX__ and AM__ ²⁾	0 V < $U_N \leq 500$ V	Enmelled wire with	+ N + CMF	
	500 V < $U_N \leq 690$ V	fiber glass taping	+ du/dt + N + CMF	
HDP	Consult the motor manufacturer.			

¹⁾ Manufactured before 1.1.1998.

²⁾ For motors manufactured before 1.1.1998, check for additional instructions with the motor manufacturer.

Non-ABB motors

Random-wound and form-wound	$U_N \leq 420$ V	Standard $\hat{U}_{LL} = 1300$ V	–	+ N or CMF
	420 V < $U_N \leq 500$ V	Standard $\hat{U}_{LL} = 1300$ V	+ du/dt	+ du/dt + N or + du/dt + CMF
		or Reinforced: $\hat{U}_{LL} = 1600$ V, 0.2 microsecond rise time	–	+ N or CMF
	500 V < $U_N \leq 600$ V	Reinforced: $\hat{U}_{LL} = 1600$ V	+ du/dt	+ du/dt + N or + du/dt + CMF
		or Reinforced: $\hat{U}_{LL} = 1800$ V	–	+ N or CMF
	600 V < $U_N \leq 690$ V	Reinforced: $\hat{U}_{LL} = 1800$ V	+ du/dt	+ du/dt + N
Reinforced: $\hat{U}_{LL} = 2000$ V, 0.3 microsecond rise time		–	+ N or CMF	

The abbreviations used in the table are defined below

Abbr.	Definition
U_N	Nominal AC line voltage.
\hat{U}_{LL}	Peak line-to-line voltage at motor terminals which the motor insulation must withstand.
P_N	Motor nominal power.
du/dt	du/dt filter at the output of the drive. Available from ABB as an optional add-on kit.
CMF	Common mode filter. Depending on the drive type, CMF is available from ABB as a factory-installed option (+208) or as an optional add-on kit.
N	N-end bearing: insulated motor non-drive end bearing.
n/a	Motors of this power range are not available as standard units. Consult the motor manufacturer.

du/dt filters

External du/dt filters for ACS880-01

ACS880			du/dt filter type (3 filters included in kits marked*)													
			Unprotected (IP00)			Protected to IP22			Protected to IP54							
400 V	500 V	690 V	NOCH0016-60	NOCH0030-60	NOCH0070-60	NOCH0120-60*)	FOCH0260-70	FOCH0320-50	NOCH0016-62	NOCH0030-62	NOCH0070-62	NOCH0120-62	NOCH0016-65	NOCH0030-65	NOCH0070-65	NOCH0120-65
02A4-3	02A1-5		x					x					x			
03A3-3	03A0-5		x					x					x			
	03A4-5		x					x					x			
04A0-3	04A8-5		x					x					x			
05A6-3	05A2-5		x					x					x			
07A2-3	07A6-5	07A3-7	x					x					x			
09A4-3		09A8-7	x					x					x			
12A6-3	11A0-5		x					x					x			
	14A2-7		x					x					x			
017A-3	014A-5			x					x					x		
	018A-7			x					x					x		
	021A-5	022A-7		x					x					x		
025A-3		026A-7		x					x					x		
	027A-5				x					x					x	
032A-3	034A-5	035A-7			x					x					x	
038A-3	040A-5	042A-7			x					x					x	
045A-3	052A-5	049A-7			x					x					x	
061A-3					x					x					x	
	065A-5	061A-7				x					x					x
072A-3	077A-5					x					x					x
087A-3		084A-7				x					x					x
105A-3	096A-5	098A-7				x					x					x
	124A-5	119A-7					x									
145A-3	156A-5	142A-7					x									
169A-3	180A-5	174A-7					x									
206A-3	240A-5	210A-7					x									
246A-3	260A-5	271A-7					x									
293A-3							x									
363A-3	361A-5							x								
430A-3	414A-5							x								

Applicability

Separate du/dt filters are available for ACS880-01. Unprotected IP00 filters must be placed into an enclosure that provides an adequate degree of protection.

Factory-installed du/dt filters are available for the ACS880-07. They are installed inside the drive cabinet.

Dimensions and weights of the du/dt filters

du/dt filter	Height (mm)	Width (mm)	Depth (mm)	Weight (kg)
NOCH0016-60	195	140	115	2.4
NOCH0016-62/65	323	199	154	6
NOCH0030-60	215	165	130	4.7
NOCH0030-62/65	348	249	172	9
NOCH0070-60	261	180	150	9.5
NOCH0070-62/65	433	279	202	15.5
NOCH0120-60 ³⁾	200	154	106	7
NOCH0120-62/65	765	308	256	45
NOCH0260-60 ³⁾	383	185	111	12
FOCH0260-70	382	340	254	47
FOCH0320-50	662	319	293	65
FOCH0610-70	662	319	293	65

³⁾ 3 filters included, dimensions apply for one filter.



NOCH0016-62



NOCH0016-60



NOCH0016-65



FOCH0610-70

Dimensioning tool for selecting the optimal drive

DriveSize is designed to help select the optimal drive, motor and transformer for the application. Based on data supplied by the user, the tool calculates and suggests which drive and motors to use. DriveSize uses technical specifications found in our technical catalogs and manuals. It provides default values which can be changed by the user.

DriveSize creates documents for drive and motor dimensioning based on the load, network and cooling data provided by the user. Dimensioning results can be viewed graphically and numerically in the tool.

The tool can be used to calculate currents and network harmonics for a single supply unit or a whole system. The user can import a user-defined motor database by using a separate template that comes with the installation package. DriveSize is easy to use and has shortcut keys to make navigation quicker.

Easy to access and use

DriveSize is a free software and can be used either online or downloaded for PC from www.abb.com/drives.





Summary of features and options

Power and voltage range	Ordering code	ACS880-01 R1 to R9	ACS880-07 R6 to R11	ACS880-07 n×R8i
		kW	kW	kW
230 V		0.55 to 75		
400 V		0.55 to 250	45 to 500	400 to 1400
500 V		0.55 to 250	45 to 560	500 to 1400
690 V		4 to 250	45 to 630	560 to 2800
Mounting				
Wall-mounting		●	–	–
For cabinet mounting	P940	□	–	–
Cabinet-built		–	●	●
Cabling				
Bottom entry and exit		●	●	●
Top entry and exit		–	□	□
Degree of protection				
IP20 (UL type 1)	P940	□	–	–
IP21 (UL type 1)		●	–	–
IP22 (UL type 1)		–	●	●
IP42 (UL type 1)	B054	–	□	□
IP54 (UL type 12)	B055	–	□	□
IP55 (UL type 12)	B056	□	–	–
Motor control				
DTC motor control		●	●	●
Software				
Primary control program, for more details see section:		●	●	●
Drive application programming with CODESYS		●	●	●
Drive application programming with CODESYS using Automation Builder	N8010	□	□	□
Application control program for winder	N5000	□ ¹⁾	□ ¹⁾	□ ¹⁾
Application control program for crane	N5050	□ ¹⁾	□ ¹⁾	□ ¹⁾
Application control program for centrifuge/decanter	N5150	□ ¹⁾	□ ¹⁾	□ ¹⁾
Application control program for PCP/ESP pump	N5200	□ ¹⁾	□ ¹⁾	□ ¹⁾
Application control program for Rod pump	N5250	□ ¹⁾	□ ¹⁾	□ ¹⁾
Support for asynchronous motor		●	●	●
Support for permanent magnet motor		●	●	●
Support for synchronous reluctance motor (SynRM)	N7502	□	□	–
Control panel				
Intuitive control panel		● ¹⁾	●	●
Integrated control panel holder in the drive		●	–	–
Control panel mounting platform (flush), DPMP-01		■	–	–
Control connections (I/O) and communications				
2 pcs analog inputs, programmable, galvanically isolated		●	●	●
2 pcs analog outputs, programmable		●	●	●
6 pcs digital inputs, programmable, galvanically isolated - can be divided into two groups		●	●	●
2 pcs digital inputs/outputs		●	●	●
1 pcs digital input interlock		●	●	●
3 pcs relay outputs programmable		●	●	●
Safe torque off (STO)		●	●	●
Drive-to-drive link/Built-in Modbus		●	●	●
Assistant control panel/PC tool connection		●	●	●
Possibility for external power supply for control unit		●	●	●
Built-in I/O extension and speed feedback modules: for more details see sections:		□	□	□
"Input/output extension modules for increased connectivity", "Speed feedback interfaces for precise process control" and "DDCS communication option modules"				
Built-in adapters for several fieldbuses: for more details see section "Flexible connectivity to automation networks"		□	□	□
EMC filters				
EMC 1 st environment, unrestricted distribution (category C2)	E202	□ ²⁾	□ ²⁾	–
EMC 2 nd environment, unrestricted distribution (category C3)	E200	□ ³⁾	□ ³⁾	–
EMC 2 nd environment, unrestricted distribution (category C3)	E201	□ ⁴⁾	□ ⁴⁾	–
EMC 2 nd environment, unrestricted distribution (category C3)	E210	–	□ ⁵⁾	●

Summary of features and options

Power and voltage range	Ordering code	ACS880-01	ACS880-07	ACS880-07
		R1 to R9	R6 to R11	n×R8i
		kW	kW	kW
230 V		0.55 to 75		
400 V		0.55 to 250	45 to 500	400 to 1400
500 V		0.55 to 250	45 to 560	500 to 1400
690 V		4 to 250	45 to 630	560 to 2800
Line filter				
AC or DC choke		●	●	●
Output filters				
Common mode filter	E202	–	□	□
du/dt filters	E205	■	□	□
Braking (see braking unit table)				
Brake chopper	D150	□ ⁶⁾	□	□ ⁷⁾
Brake resistor	D151	■	□	□ ⁷⁾
Rectifier bridge				
12-pulse	A004	–	–	□
Line side apparatus				
aR line fuses		–	●	●
Main switch		–	●	●
Line contactor	F250	–	□	□
Air circuit breaker	F255	–	–	□ ⁸⁾
Earthing switch	F259	–	–	□
Cabinet options				
Cabinet heater (ext. supply)	G300	–	□	□
Output for motor heater (ext. supply)	G313	–	□	□
Customized options	P902	–	□	□
Safety options				
Safe torque off (STO)		●	●	●
FSO-12, without encoder: Safe stop 1 (SS1)	Q973	□	□	□
FSO-12, without encoder: Safely-limited speed (SLS)	Q973	□	□	□
FSO-12, without encoder: Safe brake control (SBC)	Q973	□	□	□
FSO-12, without encoder: Safe maximum speed (SMS)	Q973	□	□	□
FSO-12, without encoder: Safe stop emergency (SSE)	Q973	□	□	□
Prevention of unexpected startup with safety relay	Q957	–	□	□
Prevention of unexpected startup with FSO-12	Q950	–	□ ⁹⁾	□ ⁹⁾
Emergency stop, category 0 with opening the main contactor/breaker, with safety relay	Q951	–	□	□
Emergency stop, category 1 with opening the main contactor/breaker	Q952	–	□	□
Emergency stop, category 0 with STO, with safety relay	Q963	–	□	□
Emergency stop, category 1 with STO, with safety relay	Q964	–	□	□
Emergency stop, configurable category 0 or 1 with opening the main contactor/breaker, with FSO-12	Q978	–	□ ⁹⁾	□ ⁹⁾
Emergency stop, configurable category 0 or 1 with STO and FSO-12	Q979	–	□ ⁹⁾	□ ⁹⁾
Safely-limited speed without encoder, with FSO-12		–	□ ⁹⁾	□ ⁹⁾
Earth fault monitoring, earthed mains		●	●	●
Earth fault monitoring, unearthed mains	Q954	–	□	□
ATEX thermal motor protection		–	□ ⁹⁾	□ ⁹⁾
Approvals				
CE		●	●	●
UL, cUL	C121	●	□ ¹⁰⁾	□
CSA	C134	● ¹³⁾	□ ¹¹⁾	□ ¹¹⁾
EAC/GOST R ¹²⁾		●	●	●
RoHS		●	●	●
C-Tick		●	●	●
Marine type approvals		□ ¹¹⁾	–	–
TÜV nord certificate for safety functions		●	□ ⁹⁾	□ ⁹⁾

- Standard
- Selectable option, with plus code
- Selectable option, external, no plus code
- Not available

Notes

¹⁾ Without control panel, OJ400

²⁾ Earthed network, frame sizes R1 to R9, 380 to 500 V

³⁾ Earthed network, frame sizes R6 to R9, 380 to 500 V

⁴⁾ Unearthed network, frame sizes R6 to R9 380 to 500 V, frame sizes R7 to R9, 690 V

⁵⁾ Earthed/unearthed network, frame sizes R10 to R11 (380 to 500 V)

⁶⁾ Frame sizes R5 to R9 as selectable option, built-in

⁷⁾ 2×R8i

⁸⁾ 2×D8T to 4×D8T

⁹⁾ Check availability from local ABB

¹⁰⁾ Frame sizes R10 to R11 pending

¹¹⁾ Pending

¹²⁾ EAC will replace GOST R

¹³⁾ CSA pending 230 V (R4 to R8)

Expertise at every stage of the value chain

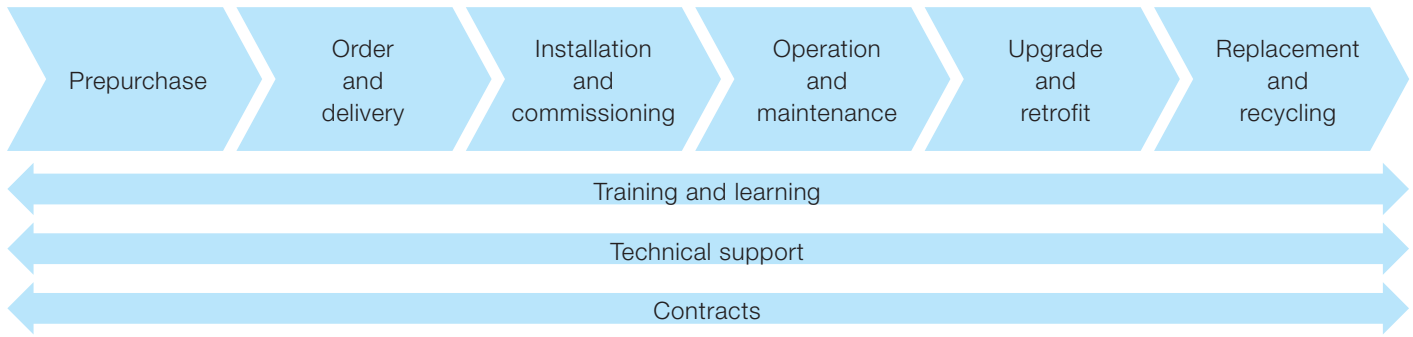

The services offered for ABB low voltage drives span the entire value chain, from the moment a customer makes the first enquiry through to disposal and recycling of the drive. Throughout the value chain, ABB provides training and learning, technical support and contracts. All of this is supported by one of the most extensive global drive sales and service networks.

Prepurchase

ABB provides a range of services that help guide the customers to the right products for their applications. Examples of services include correct drive selection and dimensioning, energy appraisal, harmonic survey and EMC assessment.

Order and delivery

Orders can be placed through any ABB office or through ABB's channel partners. Orders can be placed and tracked online.

ABB's sales and services network offers timely deliveries including express delivery.

Installation and commissioning

While many customers have the resources to undertake installation and commissioning on their own, ABB and its third party channel companies are available to advise or undertake the entire drive installation and commissioning.

Operation and maintenance

Through remote monitoring, ABB can guide the customer through a fast and efficient fault-finding procedure as well as analyze the operation of the drive and the customer's process. From maintenance assessment to preventive maintenance and reconditioning of drives, ABB has all the options covered to keep its customers' processes operational.

Should corrective maintenance of drives be needed, ABB offers on-site and workshop repair, fully backed up by the most extensive spare holding.

Upgrade and retrofit

An existing ABB drive can often be upgraded to the latest software or hardware to improve the performance of the application.

Existing processes can be economically modernized by retrofitting the latest drive technology to mechanical control equipment, such as inlet guide vanes or dampers or older generations of drives.

Instead of replacing an entire drive or drive system, it is often more economical to modernize the old installation by reusing all relevant parts of the original equipment and purchasing new where necessary.

Replacement and recycling

ABB can advise on the best replacement drive while ensuring that the existing drive is disposed in a way that meets all local environmental regulations.

Entire value chain services

The main services available throughout the value chain include:

- Training and learning – ABB offers product and application training in classrooms and on the Internet.
- Technical support – At each stage of the value chain, an ABB expert is available to offer advice to keep the customer's process or plant operational.
- Contracts – Drive care contracts and other types of agreements, from individual services through to complete drive care covering all repairs and even drive replacements, are available.

Secure uptime throughout the drive life cycle

ABB follows a four-phase model for managing the life cycles of its drives. The life cycle phases are active, classic, limited and obsolete. Within each phase, every drive series has a defined set of services.

Examples of individual services are drive selection and dimensioning, installation and commissioning, preventive and corrective maintenance, remote monitoring and intelligent diagnostics, technical support, upgrade and retrofit, replacement and recycling plus training and learning.

In the active phase the drive is in serial production. The drive, with complete life cycle services, is available for purchase.

In the classic phase, the serial production of the drive has ended. The drive, with complete life cycle services, is available for plant extensions.

In the limited phase, the drive is no longer available. The life cycle services are limited. Spare parts as well as maintenance and repair services are available as long as materials can be obtained.

In the obsolete phase, the drive is not available. ABB cannot guarantee availability of services for technical reasons or within reasonable cost.

To ensure the availability of complete life cycle services, ABB recommends that a drive is kept in the active or classic phase by upgrading, retrofitting or replacing.

In the classic phase ABB carries out an annual review for each drive life cycle plan. Should any changes to the availability or duration of the services be necessary, ABB gives a life cycle announcement indicating eventual change of life cycle phase and/or any change in the duration of services.

In the limited phase, ABB issues a life cycle phase change announcement, half a year prior to shifting the product into the obsolete phase.

Maximizing return on investment

The four-phase life cycle management model provides customers with a transparent method for managing their investment in drives. In each phase, customers clearly see what life cycle services are available, and more importantly, what services are not available. Decisions on upgrading, retrofitting or replacing drives can be made with confidence.

ABB drive life cycle management model

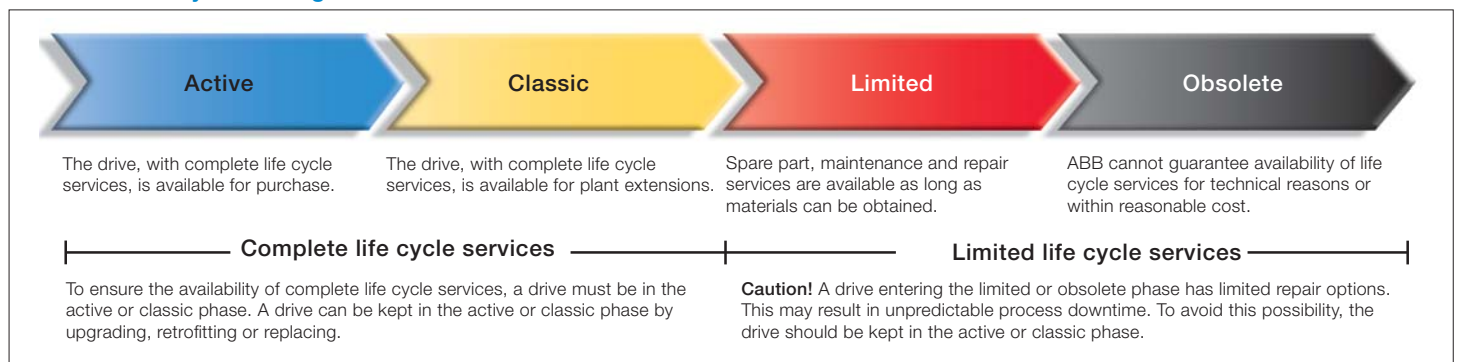

Contact us

For more information please contact your local ABB representative or visit:

www.abb.com/drives

© Copyright 2014 ABB. All rights reserved.
Specifications subject to change without notice.



ACS880 single
drives web page

3AUJ0000139403 REV I US 10.10.2014 #17245

Power and productivity
for a better world™

