

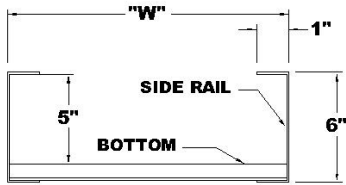

S6M61 - S9M61 - S12M61

**NEMA
12B+**



TRAY CROSS SECTION

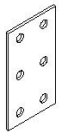

**SPLICE PLATE
(SSP-M2)**

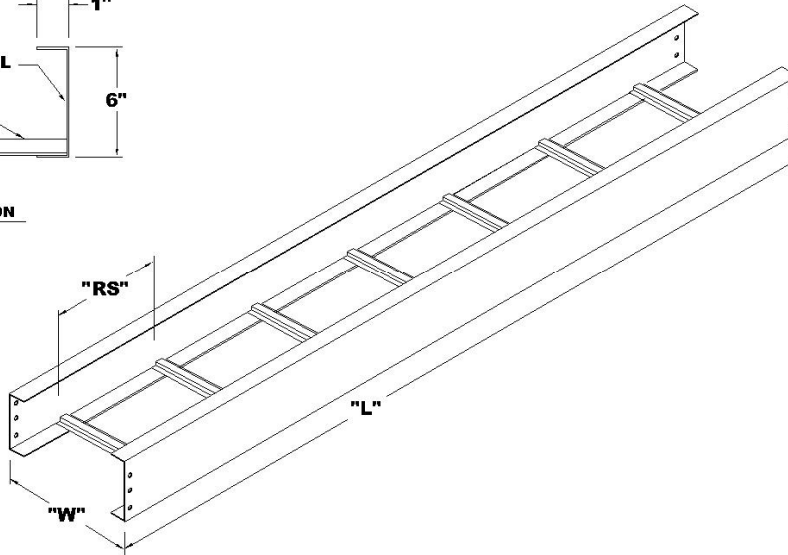

RUNG CROSS SECTION

NEMA TRAY TYPE	LADDER
NEMA / CSA CLASS	NEMA 12B+ (Exceeds NEMA 12B, 12A, 8C, 8B, 8A) 95 LBS/FT. ON A 12' SPAN WITH A 1.5 SAFETY FACTOR UL CLASSIFIED AS AN EGC, 0.7 AREA, RATED 200 AMPS
MATERIAL/FINISH	STEEL / HOT DIP GALVANIZED AFTER FABRICATION
<i>EACH STRAIGHT SECTION INCLUDES SPLICE CONNECTORS AND HARDWARE</i>	

CAT# PREFIX			-	CHOOSE	-	TRAY LENGTH			
CHOOSE RUNG SPACING			-	WIDTH	-	CHOOSE TRAY LENGTH			
6" RS	9" RS	12" RS	-		-	10 FT	12 FT	20 FT	24 FT
S6M61	S9M61	S12M61	-	6, 9, 12 , 18, 24, 30, 36	-	120	144	N/A	N/A

SAMPLE CATALOG NUMBER - 9" Rung Spacing, 12" Wide, 12' Long

S9M61- 12- 144

NEMA LOAD AND DEFLECTION TABLE					
	4 FT SPAN	6 FT SPAN	8 FT SPAN	10 FT SPAN	12 FT SPAN
LOAD LBS/FT	855	380	214	137	95
DEFLECTION	0.05"	0.11"	0.19"	0.29"	0.42"

COMMON FITTINGS for S6M61 - S9M61 - S12M61 SYSTEMS



The Prefix SLM61 is used on all fittings. Example: SLM61-6H90-24 6" Wide, Horiz. 90° Bend, 24" Radius
 Here are some typical fitting catalog numbers: Change the number shown in **red** to change the **width**, the **blue** to change **degree** of bend or **green** to change **radius**

SLM61-6H90-12	6" WIDE HORIZ. 90° BEND WITH 12" RADIUS
SLM61-12H60-24	12" WIDE HORIZ. 60° BEND WITH 24" RADIUS
SLM61-18H45-36	18" WIDE HORIZ. 45° BEND WITH 36" RADIUS
SLM61-24H30-12	24" WIDE HORIZ. 30° BEND WITH 12" RADIUS
SLM61-30T-24	30" WIDE HORIZ. TEE WITH 24" RADIUS
SLM61-36X-36	36" WIDE HORIZ. CROSS WITH 36" RADIUS
SLM61-6VI90-12	6" WIDE VERT. INSIDE 90° WITH 12" RADIUS
SLM61-9VI60-24	9" WIDE VERT. INSIDE 60° WITH 24" RADIUS
SLM61-12VI45-36	12" WIDE VERT. INSIDE 45° WITH 36" RADIUS
SLM61-18VI30-12	18" WIDE VERT. INSIDE 30° WITH 12" RADIUS
SLM61-24VO90-24	24" WIDE VERT. OUTSIDE 90° WITH 24" RADIUS
SLM61-30VO60-36	30" WIDE VERT. OUTSIDE 60° WITH 36" RADIUS
SLM61-36VO45-12	36" WIDE VERT. OUTSIDE 45° WITH 12" RADIUS
SLM61-6VO30-24	6" WIDE VERT. OUTSIDE 30° WITH 24" RADIUS
SLM61-36R24	36" WIDE TO 24" WIDE STRAIGHT REDUCER
SLM61-24RL12	24" WIDE TO 12" WIDE LEFT HAND REDUCER
SLM61-12RR6	12" WIDE TO 6" WIDE RIGHT HAND REDUCER

TYPICAL ACCESSORIES for S6M61 - S9M61 - S12M61 TRAY SYSTEM

SHDC-V	HOLD DOWN CLAMP (STEEL)	S5S-144	STRAIGHT SEPARATOR
SEXG-VL	EXPANSION GUIDE (STEEL)	S5S-HA	HORIZ. FITTING SEPARATOR
SSP-M2	STANDARD SPLICE CONN.	SEP- (*)-6	BLIND END PLATE
SSP-6-EX	EXPANSION SPLICE CONN.	VBC- (*)-6	BOX CONNECTOR
SFS-H6	HORIZ. HINGE CONNECTOR	SVD- (*)-XA	CABLE DROPOUT
SFS-V6	VERT. HINGE CONNECTOR	AFS-C	600 AMP BONDING JUMPER
SHC-100	TRAY HANGER CLIP (STEEL)	SSP-6-90	90° SPLICE CONNECTOR
(*) INSERT TRAY WIDTH		(*) INSERT TRAY WIDTH	

COVERS (Mill-Galvanized) for S6M61 - S9M61 - S12M61 TRAY SYSTEM

CS1S2-12-144	12" WIDE FLAT SOLID COVER 12' LONG
CS1F2-18-144	18" WIDE FLAT FLANGED COVER 12' LONG
CS1F2-24-144-L	24" WIDE FLANGED LOUVERED COVER 12' LONG
CS1F2-36H90-24	TYPICAL FITTING FLANGED COVER, HORIZ. 90°, 36" WIDE, 24" RADIUS