

268G or 268P

SERIES II STEEL TYPE CABLE TRAY
 6" NOMINAL OUTSIDE DEPTH
 5" NEMA LOADING DEPTH
 PRE-GALV. ASTM A525
 HOT DIP GALVANIZED (AFTER FAB.) ASTM A123
 CONSTRUCTED AND LOAD TESTED PER NEMA VE1/CSA
 C22.2 NO. 126
 NEMA CLASS: 16A, 12C
 CSA CLASS: D1-3M
 UL CROSS SECTIONAL AREA: .70 SQ. IN.
 CLASSIFIED BY UNDERWRITERS LABORATORIES, INC.
 AS TO IT'S SUITABILITY AS AN EQUIPMENT
 GROUNDING CONDUCTOR ONLY. 556E

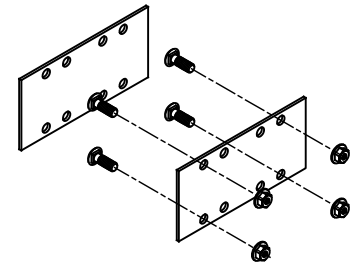
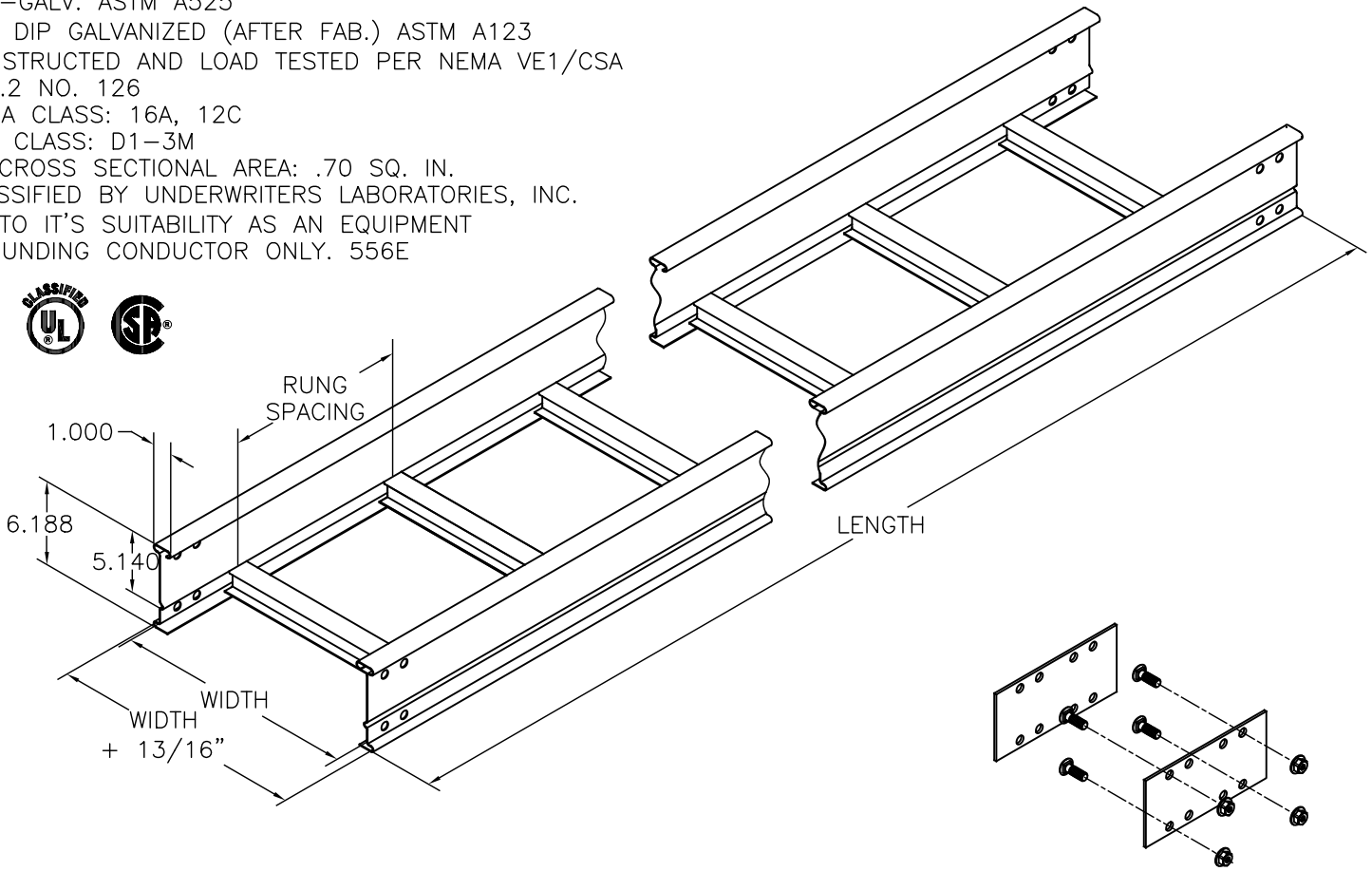

UTILIZES 1 PAIR
 9(*)-8006 STEEL
 SPLICE PLATES WITH (16)
 3/8" ZINC PLATED
 HARDWARE
 (*) INSERT ZN OR G
 TORQUE BOLTS TO 19
 FT./LBS.

268 P 09-12-144				
SERIES	MATERIAL	RUNG SPACING	WIDTH	LENGTH
268	P=PRE-GALVANIZED G=HDGAF	(INCHES)	(INCHES)	(INCHES)
		06	06	144
		09	09 30	120
		12	12 36	288
			18 42	240
			24 48	

B-LINE SERIES	SAFETY FACTOR	SPAN (FT.)	6	8	10	12	14	16
268	1.5	LOAD LBS./FT.	441	248	159	110	81	62
		DEFLECTION IN.*	.1323	.2232	.3657	.517	.7128	.93
		DEFLECTION MULTIPLIER	.0003	.0009	.0023	.0047	.0088	.015

*TO DETERMINE DEFLECTION (INCHES) AT ANY LESSER LOAD, MULTIPLY THE ACTUAL LOAD (LBS./FT.) BY THE DEFLECTION MULTIPLIER.

LOAD RATINGS ARE 6" - 36" WIDE. 42" MUST BE DERATED BY 10% AND 48" DERATED BY 20%.



EATON, B-LINE DIVISION
 509 WEST MONROE STREET
 HIGHLAND, ILLINOIS 62249-0326
 PHONE (618) 654-2184
 FAX (618) 654-5499

TITLE: 268
 SERIES II CABLE TRAY

PRODUCT DWG. NO'S:
 4095

SHEET OF
 DRAWN BY: JSH

EQUIPMENT FURNISHED HAS BEEN FABRICATED
 IN ACCORDANCE WITH THIS DRAWING.

DRAWING NO.
 S00004095-268

THIS DRAWING AND/OR THE TECHNICAL INFORMATION CONTAINED HEREON IS THE PROPERTY OF EATON CORPORATION ("EATON"), AND IS ISSUED IN CONFIDENCE FOR EATON ENGINEERING PURPOSES ONLY AND MAY NOT BE REPRODUCED OR USED FOR ANY PURPOSE WHATSOEVER WITHOUT THE EXPRESS WRITTEN PERMISSION OF EATON TO THE USER. THIS DRAWING AND/OR TECHNICAL INFORMATION IS THE PROPERTY OF EATON AND IS LOANED FOR MUTUAL ASSISTANCE, TO BE RETURNED WHEN ITS INTENDED PURPOSE HAS BEEN SERVED.

DATE: 1-4-01