

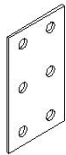

# A( )MB1 - "W" - "L"

**NEMA  
12C**

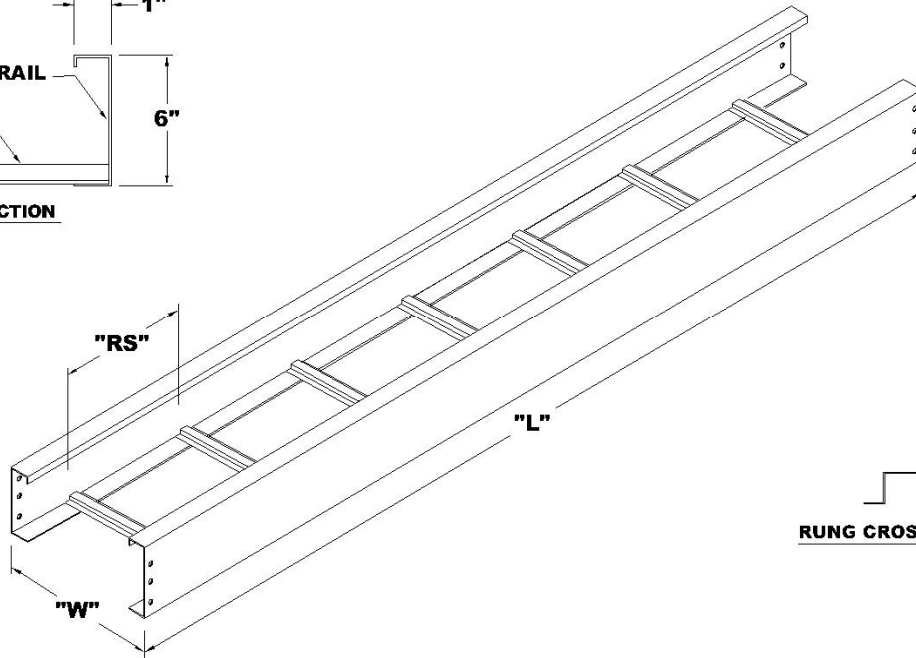
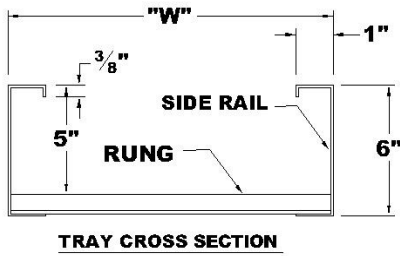

**SPLICE PLATE  
( ASP-M2 )**



<b>NEMA TRAY TYPE</b>	LADDER
<b>NEMA / CSA CLASS</b>	<b>NEMA 12C (Exceeds NEMA 12B, 12A, 8C, 8B, 8A) 100 LBS/FT. ON A 12' SPAN WITH A 1.5 SAFETY FACTOR UL CLASSIFIED AS AN EGC, 1.0 AREA, RATED 1200 AMPS</b>
<b>MATERIAL/FINISH</b>	ALUMINUM / NATURAL
<i>EACH STRAIGHT SECTION INCLUDES SPLICE CONNECTORS AND HARDWARE</i>	

CAT# PREFIX			-	CHOOSE	-	TRAY LENGTH			
CHOOSE RUNG SPACING			-	WIDTH	-	CHOOSE TRAY LENGTH			
6" RS	9" RS	12" RS	-		-	10 FT	12 FT	20 FT	24 FT
A6MB1	<b>A9MB1</b>	A12MB1	-	6, 9, <b>12</b> , 18, 24, 30, 36, 42, 48	-	120	<b>144</b>	N/A	N/A

**SAMPLE CATALOG NUMBER - 9" Rung Spacing, 12" Wide, 12' Long**

A9MB1-
12-
144

<b>NEMA LOAD AND DEFLECTION TABLE</b>					
	4 FT SPAN	6 FT SPAN	8 FT SPAN	10 FT SPAN	12 FT SPAN
<b>LOAD LBS/FT</b>	810	436	245	157	109
<b>DEFLECTION</b>	0.09"	0.20"	0.36"	0.56	0.80"

## COMMON FITTINGS for A6MB1 - A9MB1 - A12MB1 SYSTEMS



The Prefix ALMB1 is used on all fittings. Example: ALMB1-6H90-24- 6" Wide, Horiz. 90° Bend, 24" Radius. Here are some typical fitting catalog numbers: Change the number shown in **red** to change the **width**, the **blue** to change **degree** of bend or **green** to change **radius**

ALMB1-6H90-12	6" WIDE HORIZ. 90° BEND WITH 12" RADIUS
ALMB1-12H60-24	12" WIDE HORIZ. 60° BEND WITH 24" RADIUS
ALMB1-36H45-36	36" WIDE HORIZ. 45° BEND WITH 36" RADIUS
ALMB1-24H30-12	24" WIDE HORIZ. 30° BEND WITH 12" RADIUS
ALMB1-30T-24	30" WIDE HORIZ. TEE WITH 24" RADIUS
ALMB1-36X-36	36" WIDE HORIZ. CROSS WITH 36" RADIUS
ALMB1-6VI90-12	6" WIDE VERT. INSIDE 90° WITH 12" RADIUS
ALMB1-9VI60-24	9" WIDE VERT. INSIDE 60° WITH 24" RADIUS
ALMB1-12VI45-36	12" WIDE VERT. INSIDE 45° WITH 36" RADIUS
ALMB1-18VI30-12	18" WIDE VERT. INSIDE 30° WITH 12" RADIUS
ALMB1-24VO90-24	24" WIDE VERT. OUTSIDE 90° WITH 24" RADIUS
ALMB1-30VO60-36	30" WIDE VERT. OUTSIDE 60° WITH 36" RADIUS
ALMB1-36VO45-12	36" WIDE VERT. OUTSIDE 45° WITH 12" RADIUS
ALMB1-6VO30-24	6" WIDE VERT. OUTSIDE 30° WITH 24" RADIUS
ALMB1-36R24	36" WIDE TO 24" WIDE STRAIGHT REDUCER
ALMB1-24RL12	24" WIDE TO 12" WIDE LEFT HAND REDUCER
ALMB1-12RR6	12" WIDE TO 6" WIDE RIGHT HAND REDUCER

### TYPICAL ACCESSORIES for A6MB1 - A9MB1 - A12MB1 TRAY SYSTEM

SHDC-V	HOLD DOWN CLAMP (STEEL)	A5S-144	STRAIGHT SEPARATOR
SEXG-VL	EXPANSION GUIDE (STEEL)	A5S-HA	HORIZ. FITTING SEPARATOR
ASP-M2	STANDARD SPLICE CONN.	AEP- (*)-6	BLIND END PLATE
ASP-6-EX	EXPANSION SPLICE CONN.	AVBC- (*)-6	BOX CONNECTOR
AFS-H6	HORIZ. HINGE CONNECTOR	AVD- (*)-XA	CABLE DROPOUT
AFS-V6	VERT. HINGE CONNECTOR	AFS-C	600 AMP BONDING JUMPER
SHC-100	TRAY HANGER CLIP (STEEL)	ASP-6-90	90° SPLICE CONNECTOR
(*) INSERT TRAY WIDTH		(*) INSERT TRAY WIDTH	

### COVERS for A6MB1 - A9MB1 - A12MB1 TRAY SYSTEM

CA1S-12-144	12" WIDE FLAT SOLID COVER 12' LONG
CA1F-18-144	18" WIDE FLAT FLANGED COVER 12' LONG
CA1F-24-144-L	24" WIDE FLANGED LOUVERED COVER 12' LONG
CA1F-36H90-24	TYPICAL FITTING FLANGED COVER, HORIZ. 90°, 36" WIDE, 24" RADIUS