

## VIBRATONE® HORNS (350/450)

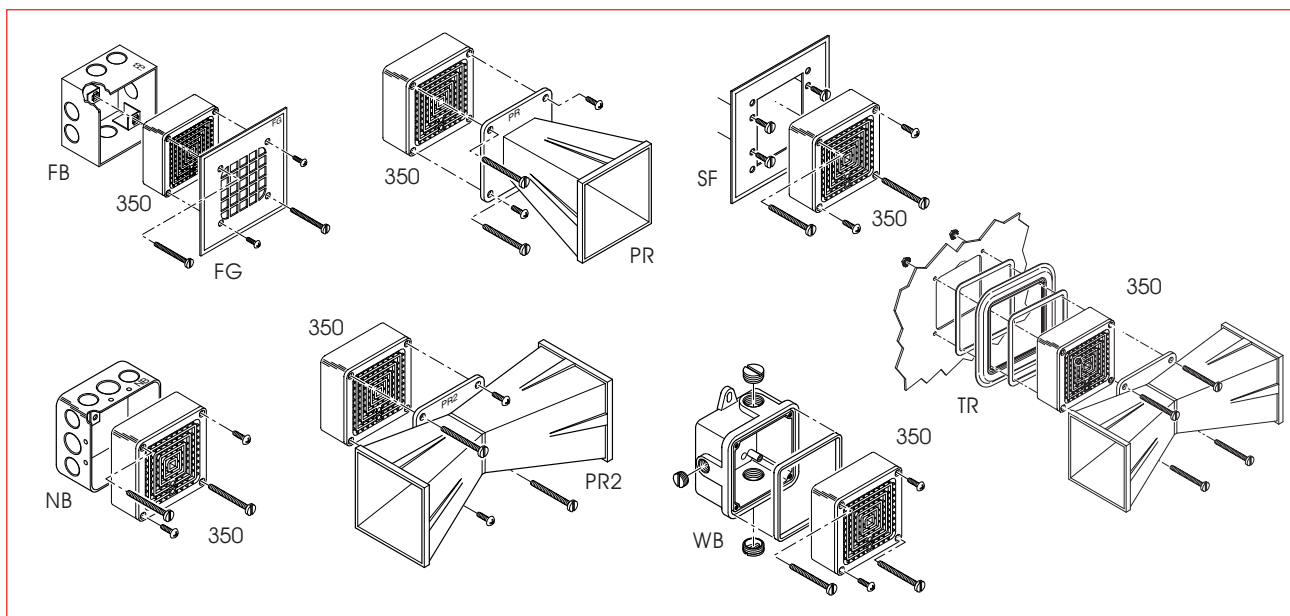

### OPTIONS

- FB** Wall box for flush mounting the Vibratone® horn in stud, 4" block, or other shallow wall construction; 4<sup>3/8</sup>" square box; 2<sup>7/8</sup>" deep; shipping weight 2 lbs. (0.91 kg)
- FBL** Same as FB, but 3<sup>13/16</sup>" deep for 6" x 8" concrete block, cinder block or other deep wall construction; shipping wt. 3 lbs. (1.36 kg)
- FG** Flush grille which attaches to the basic unit and serves as the cover of the plastered-in FB flush box; 6" H x 6" W x 1<sup>1/8</sup>" D; shipping wt. 1 lb. (0.45 kg)
- K8435666A** Optional Panel Mounting Gasket Kit includes a gasket and hardware for surface or flush mounting the horn for NEMA Type 4 applications.
- NB** 4" square box with 1/2" & 3/4" knockouts for interior mountings; 1 1/2" deep; shipping weight 1 lb. (0.45 kg)
- PR** Projector which concentrates sound into a basic area when attached to the basic model 350/450 units; 4" H x 4" W x 6" D; shipping weight 1 lb. (0.45 kg)
- PR2** Double projector directs sounds to both sides when attached to the basic model 350/450 units; ideal for use in hallways; 4" H x 11 1/2" W x 4" D; shipping weight 2 lbs. (0.91 kg)
- SF** Stamped surface plate used for installations on plastered-in 4" outlet switch boxes for semi-flush mountings; 6"H x 6" W x 1/2" D; shipping weight 1 lb. (0.45 kg)
- TR** Gasketed trim ring allowing surface mount installations of 350/450 units while maintaining Type12 and Type4X rating of enclosure.
- WB** Cast aluminum neoprene-gasketed weatherproof housing for outside use, complete with mounting lugs; tapped for 1/2", 3/4" conduit; 4<sup>3/8</sup>" square box; 2" deep mounting lugs on 4 1/2" centers; shipping weight 1 lb. (0.45 kg)

### HOW TO ORDER

- Specify model and voltage
- Specify options from list
- Please refer to Model Number Index 350/450 beginning on page 377

### REPLACEMENT PARTS

<i>Description</i>	<i>Part Number</i>
Panel Mount Gasket Kit	K8435666A
Coil (120VAC only)	KFC1516C
Volume Control Kit	K8435663B
Gasket for WB	K8435696A

### SPECIFICATIONS

Operating Temperature:	-65°F to 150°F	-54°C to 66°C
Net Weight:	1.4 lbs.	0.6 kg
Shipping Weight:	1.5 lbs.	0.7 kg
Height:	4.0"	102.0 mm
Width:	4.0"	102.0 mm
Depth:	2.5"	64.0 mm