

capacitive sensor BC10-P30SR-FZ3X2

TURCK

Industrial
Automation

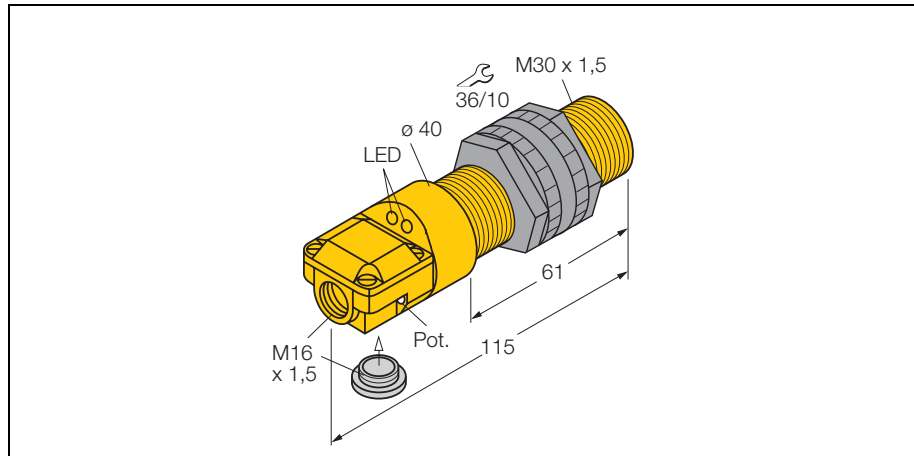

- 2 cable entries (axial, radial)
- threaded barrel, M30 x 1.5
- plastic, ABS
- fine adjustment via potentiometer
- AC 2-wire, 20...250 VAC
- connection programmable (n.c./n.o.)
- Terminal chamber

Wiring diagram

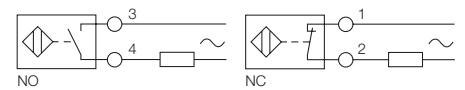

Capacitive proximity switches are designed for non-contact and wear-free detection of metal (electrically conductive) and non-metal (electrically non-conductive) objects.

Type	BC10-P30SR-FZ3X2
Ident-No.	23104
Rated operating distance Sn	10 mm, flush mounting
Rated operating distance Sn	15 mm, non-flush mounting
Hysteresis	2... 20 %
Temperature drift	≤ ± 20 %
Repeatability	≤ 2 %
Ambient temperature	-25...+ 70 °C
Operating voltage	20... 250VAC
AC rated operational current	≤ 500 mA
Frequency	50... 60 Hz
Smallest operating current I _m	≥ 5 mA
Residual current	≤ 1.7 mA
Switching frequency	≤ 0.02 kHz
Rated insulation voltage	≤ 1.5 kV
Output function	2-wire, connection programmable
Voltage drop at I _e	≤ 7V
Housing	threaded barrel, M30 x 1.5
Dimensions	115 mm
Housing material	plastic, ABS
Material active face	plastic, ABS
Tightening torque of housing nut	5 Nm
Connection	Terminal chamber
Vibration resistance	55 Hz (1 mm)
Shock resistance	30g (11 ms)
Degree of protection	IP67
Operating voltage display	LED green
Display switch state	LED yellow
Included in scope of supply	blanking plug

capacitive sensor
BC10-P30SR-FZ3X2

TURCK

Industrial
Automation

Accessories

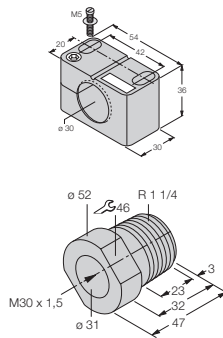
Type code	Ident-No.	Short text	Dimension drawing
BST-30B	6947216	fixing clamp with dead-stop; material: PA6	
MAP-M30	6950013	mounting adapter; material: Polypropylene; sensor replacement with filled container possible (adapter remains in container during sensor replacement)	