

## capacitive sensor BC5-S18-AP4X

**TURCK**

Industrial  
Automation

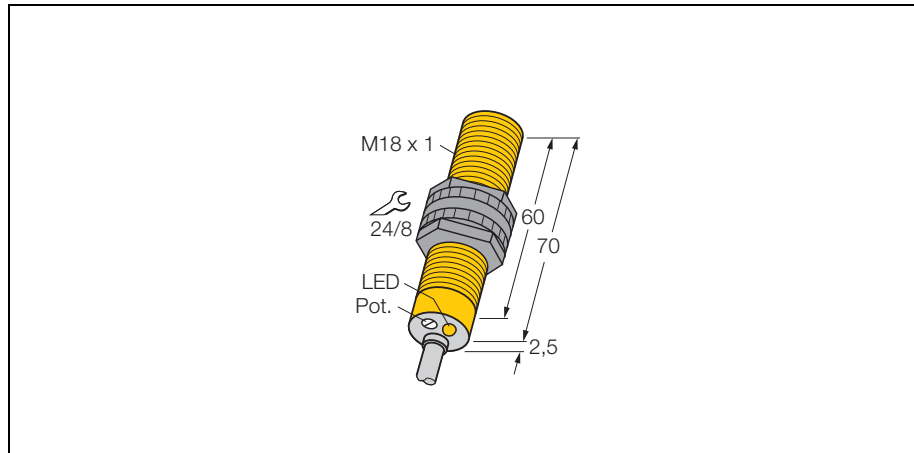

- Threaded barrel, M18 x 1
- plastic, PA12-GF30
- fine adjustment via potentiometer
- 3-wire DC, 10...65 VDC
- normally open, pnp output
- cable connection

### Wiring diagram

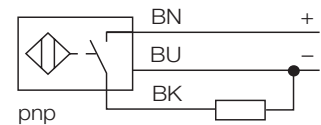

Capacitive proximity switches are designed for non-contact and wear-free detection of metal (electrically conductive) and non-metal (electrically non-conductive) objects.

<b>Type</b>	BC5-S18-AP4X
Ident-No.	25030
<b>Rated operating distance Sn</b>	5 mm, flush mounting
Rated operating distance Sn	7.5 mm, non-flush mounting
Hysteresis	2... 20 %
Temperature drift	≤ ± 20 %
Repeatability	≤ 2 %
Ambient temperature	-25...+ 70 °C
<b>Operating voltage</b>	10... 65VDC
Residual ripple	≤ 10 % U <sub>ss</sub>
DC rated operational current	≤ 200 mA
No-load current I <sub>0</sub>	≤ 15 mA
Residual current	≤ 0.1 mA
Switching frequency	≤ 0.1 kHz
Rated insulation voltage	≤ 0.5 kV
Output function	3-wire, normally open, pnp
Short-circuit protection	yes / cyclic
Voltage drop at I <sub>e</sub>	≤ 1.8V
Wire breakage / Reverse polarity protection	yes / complete
<b>Housing</b>	threaded barrel, M18 x 1
Dimensions	70 mm
Housing material	plastic, PA12-GF30
Material active face	plastic, PA12-GF30
Tightening torque of housing nut	2 Nm
Connection	cable
Cable quality	Ø 5.2, LifYY, PVC, 2 m
Cable cross section:	3 x 0.34mm <sup>2</sup>
Vibration resistance	55 Hz (1 mm)
Shock resistance	30g (11 ms)
Degree of protection	IP67
<b>Display switch state</b>	LED yellow

capacitive sensor  
BC5-S18-AP4X

**TURCK**

Industrial  
Automation

Accessories

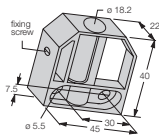
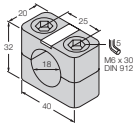
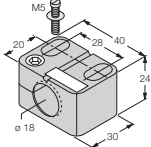
Type code	Ident-No.	Short text	Dimension drawing
BS18	69471	fixing clamp; material: PA66-GF	
BSN18	69472	fixing clamp; material: PA66-GF	
BST-18B	6947214	fixing clamp with dead-stop; material: PA6	
MAP-M18	6950012	mounting adapter; material: Polypropylene; sensor replacement with filled container possible (adapter remains in container during sensor replacement)	