

WIRING DIAGRAM

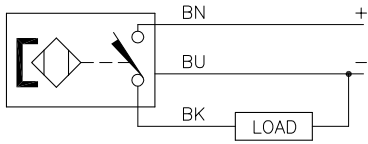

OUTPUT: AP6X

SHORT-CIRCUIT AND OVERLOAD PROTECTED

SPECIFICATIONS

PASS SPEED	≤ 10 m/s
HYSTERESIS	≤ 1mm
TEMPERATURE DRIFT	≤ 0.1mm
MIN. ABSOLUTE REPEAT ACCURACY	≥ ±0.1mm
OPERATING TEMPERATURE	-25°C to +70°C (-13°F to +158°F)
RATED OPERATIONAL VOLTAGE	10-30 VDC
MAX. RIPPLE	≤ 10%
DC RATED OPERATIONAL CURRENT	≤ 150 mA
NO-LOAD CURRENT	≤ 15 mA
RESIDUAL CURRENT	≤ 0.1 mA
MAX. SWITCHING FREQUENCY	≤ 1.0 kHz
RATED INSULATION VOLTAGE	≤ 0.5 kV
OUTPUT FUNCTION	NORMALLY OPEN, 3-WIRE, PNP
SHORT-CIRCUIT PROTECTION	YES, CYCLIC
MAX. VOLTAGE DROP	≤ 1.8 V
WIRE BREAKAGE PROTECTION	INCORPORATED
REVERSE POLARITY PROTECTION	INCORPORATED
HOUSING MATERIAL	PLASTIC, PP
ACTIVE FACE MATERIAL	PLASTIC, PP
CABLE	∅3.0, LifYY-11Y, TPU
VIBRATION	55 Hz, 1 mm AMPLITUDE (IN ALL 3 PLANES)
SHOCK	30 g, 11 ms
DEGREE OF PROTECTION	IP67
SWITCHING STATUS INDICATION	LED, YELLOW
INCLUDED IN SCOPE OF SUPPLY	CABLE CLIP

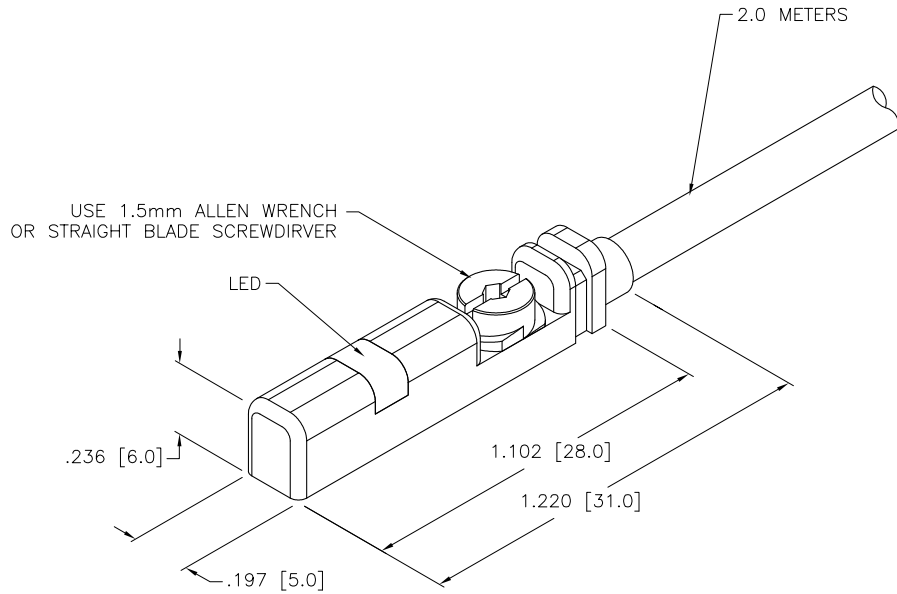

SOURCE DRAWING - FOR REFERENCE ONLY

RELATED DOCUMENTS 1. 2. 3. 4.	3RD ANGLE PROJECTION 	THIS DRAWING IS CONFIDENTIAL AND THE PROPERTY OF TURCK INC. USE OF THIS DOCUMENT WITHOUT WRITTEN PERMISSION IS PROHIBITED.		3000 CAMPUS DRIVE MINNEAPOLIS, MN 55441 1-800-544-7769 (763) 553-7300 (763) 553-0708 fax turck.com	
	MATERIAL	ALL DIMENSIONS DISPLAYED ON THIS DRAWING ARE FOR REFERENCE ONLY	DRFT RDS DSGN SD	DATE 05/18/07 SCALE 1=.5	DESCRIPTION BIM-UNT-AP6X
FINISH	CONTACT TURCK FOR MORE INFORMATION	UNIT OF MEASUREMENT INCH [MILLIMETER]		IDENTIFICATION NO. S4685720	REV B
DO NOT SCALE THIS DRAWING		FILE: S4685720		SHEET 1 OF 1	

B	DRAWING PROCESSED AS PART OF ECO 33971	CBM	04/06/11	33971
REV	DESCRIPTION	BY	DATE	ECO NO.