

RJ45S END VIEW

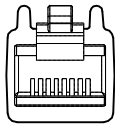

12345678

- 1 = WHITE/ORANGE (+TX)
- 2 = ORANGE (-TX)
- 3 = WHITE/GREEN (+RX)
- 4 = BLUE
- 5 = WHITE/BLUE
- 6 = GREEN (-RX)
- 7 = WHITE/BROWN
- 8 = BROWN



SPECIFICATIONS

CONTACT CARRIER MATERIAL/COLOR (RJ45S)	POLYCARBONATE/CLEAR
MOLDED HEAD MATERIAL/COLOR (RJ45S)	TPU/BLACK
CONTACT MATERIAL/PLATING (RJ45S)	BRONZE/GOLD
RATED CURRENT [A]	1.5 A
RATED VOLTAGE [V]	42 V
OUTER CABLE JACKET MATERIAL/COLOR	TPE/TEAL
CONDUCTOR INSULATION MATERIAL	HDPE
SHIELDING	ALUM.-POLYESTER FOIL, TINNED-COPPER BRAIDED
NUMBER OF CONDUCTORS [AWG]	4UTP×24 AWG, STRANDED
TEMPERATURE RANGE	-40°C to +80°C (-40°F to +176°F)
PROTECTION CLASS	NEMA 1 AND IEC IP20

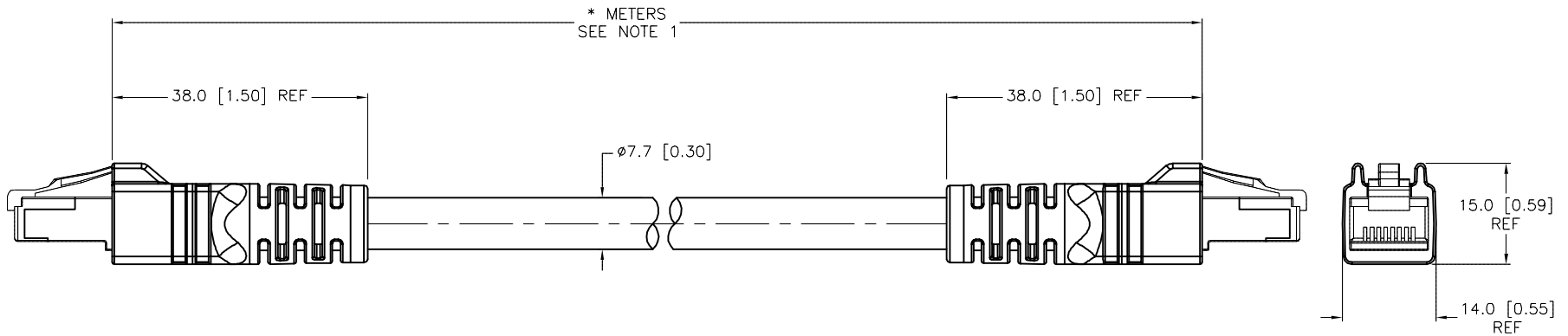

"841" RAW CABLE SPECIFICATIONS

CABLE PROPERTIES:	OIL, UV, WELD SLAG, AND ABRASION RESISTANT
VOLTAGE RATINGS (MAX):	600V
CATEGORY:	CAT 5e; (CABLE WILL MEET CAT 5e CHANNEL REQUIREMENTS TO 90M LENGTH)
POE COMPLIANT (802.3af):	UP TO 80M LENGTH WHEN INSTALLED PER RECOMMENDATIONS IN TIA TSB-184
FLEXLIFE:	10X CABLE OD MIN: 1 MILLION CYCLES (TICK TOCK) 20X CABLE OD MIN: 10 MILLION CYCLES (TICK TOCK)
APPROVALS:	TORSION TEST: 3 MILLION CYCLES (1lb LOAD, 360°-71 CYCLES/min) C(UL)US CMX-OUTDOOR-CM LISTED, AWM RECOGNIZED COMPLIANT WITH NEC ARTICLE 800 COMMUNICATIONS CABLES

CABLE LENGTH	TOLERANCE*
ALL LENGTHS	+ 4% (OR 50mm) OF LENGTH - 0% (OR 0mm) OF LENGTH WHICHEVER IS GREATER
STRIP LENGTH	TOLERANCE*
0-7mm	±0.5mm
8-29mm	±1.0mm
30-49mm	±2.0mm
50-69mm	±3.0mm
70-100mm	±4.0mm
OVER 100mm	±5.0mm

* UNLESS OTHERWISE SPECIFIED

NOTES:

1. "*" INDICATES CABLE LENGTH IN METERS. CONTACT TURCK TO ORDER SPECIFIC LENGTHS.

SOURCE DRAWING - FOR REFERENCE ONLY

RELATED DOCUMENTS 1. 2. 3. 4.	3RD ANGLE PROJECTION 	THIS DRAWING IS CONFIDENTIAL AND THE PROPERTY OF TURCK INC. USE OF THIS DOCUMENT WITHOUT WRITTEN PERMISSION IS PROHIBITED.		3000 CAMPUS DRIVE MINNEAPOLIS, MN 55441 1-800-544-7769 (763) 553-7300 (763) 553-0708 fax turck.com	
		DRFT DF APVD DF	DATE 02/20/02 SCALE 1=1.0	DESCRIPTION RJ45S RJ45S 841-*M	
MATERIAL		UNIT OF MEASUREMENT MILLIMETER [INCH]		DO NOT SCALE THIS DRAWING	
FINISH		CONTACT TURCK FOR MORE INFORMATION		FILE: 777005956	

M	ADD CABLE SPECIFICATIONS	KMY	08/08/14	46545
REV	DESCRIPTION	BY	DATE	ECO NO.