

FEMALE END VIEW

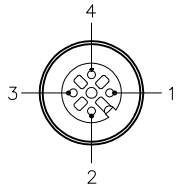

- 1 = BROWN
- 2 = WHITE
- 3 = BLUE
- 4 = BLACK



WIRING DIAGRAM

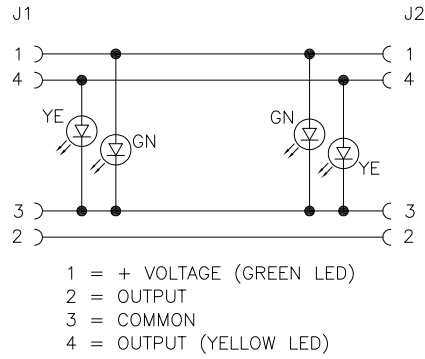

SPECIFICATIONS

| | |
|-------------------------------|-----------------------------------|
| CONTACT CARRIER MATERIAL | NYLON OR TPU |
| MOLDED HEAD MATERIAL/COLOR | TPU/CLEAR |
| CONTACT MATERIAL/PLATING | BRASS/GOLD |
| COUPLING NUT MATERIAL/PLATING | BRASS/NICKEL |
| RATED CURRENT [A] | 4.0 A |
| RATED VOLTAGE [V] | 10-30 VDC |
| OUTER JACKET MATERIAL/COLOR | PVC/YELLOW |
| CONDUCTOR INSULATION MATERIAL | PVC |
| NUMBER OF CONDUCTORS [AWG] | 4x22 AWG |
| TEMPERATURE RANGE | -40°C to +105°C (-40°F to +221°F) |
| PROTECTION CLASS | MEETS NEMA 1,3,4,6P AND IEC IP68 |

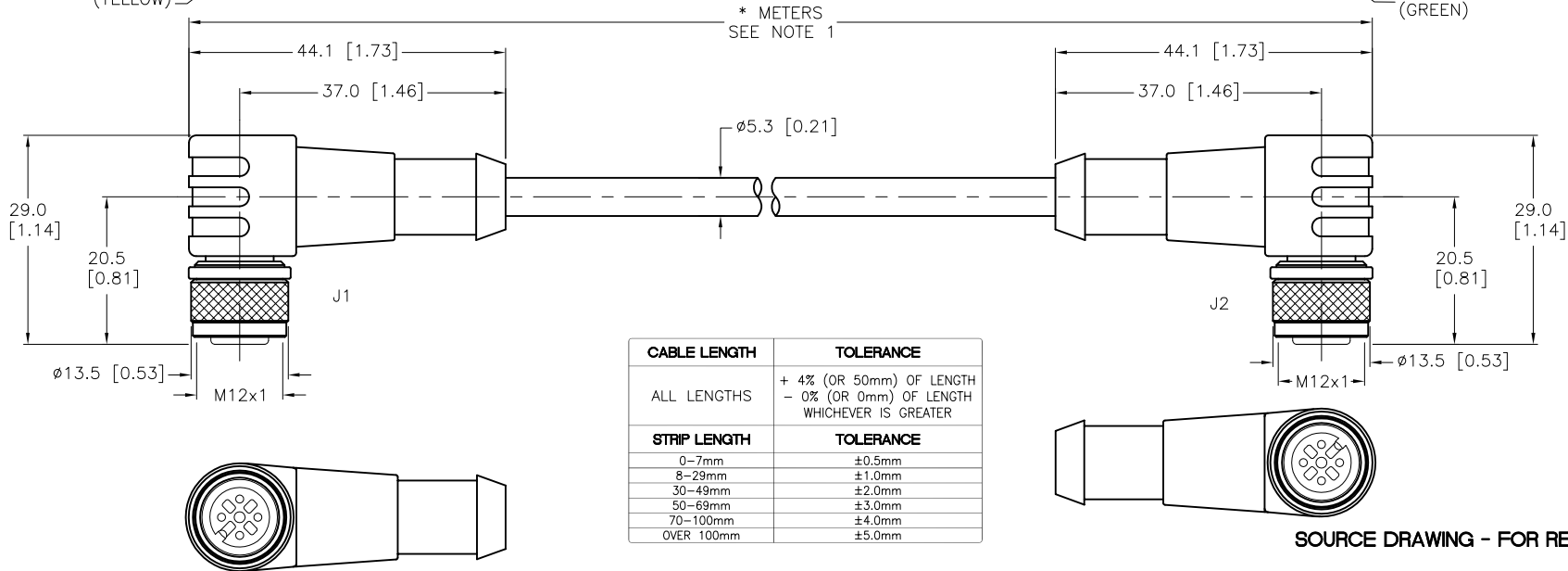
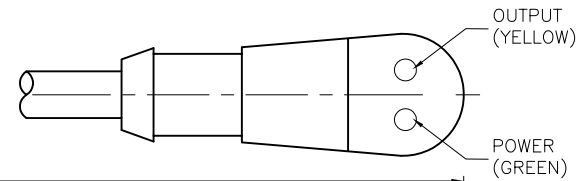
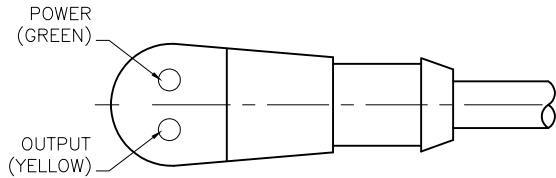

| CABLE LENGTH | TOLERANCE |
|--------------|---|
| ALL LENGTHS | + 4% (OR 50mm) OF LENGTH - 0% (OR 0mm) OF LENGTH WHICHEVER IS GREATER |
| STRIP LENGTH | TOLERANCE |
| 0-7mm | ±0.5mm |
| 8-29mm | ±1.0mm |
| 30-49mm | ±2.0mm |
| 50-69mm | ±3.0mm |
| 70-100mm | ±4.0mm |
| OVER 100mm | ±5.0mm |

SOURCE DRAWING - FOR REFERENCE ONLY

NOTES:

1. "*" DESIGNATES CABLE LENGTH IN METERS. CONTACT TURCK TO ORDER SPECIFIC LENGTHS.

| | | | | | |
|---|------------------------------------|--|---|---|---|
| RELATED DOCUMENTS 1. 2. 3. 4. | 3RD ANGLE PROJECTION | THIS DRAWING IS CONFIDENTIAL AND THE PROPERTY OF TURCK INC. USE OF THIS DOCUMENT WITHOUT WRITTEN PERMISSION IS PROHIBITED. | | 3000 CAMPUS DRIVE MINNEAPOLIS, MN 55441 1-800-544-7769 (763) 553-7300 (763) 553-0708 fax turck.com | |
| | MATERIAL SEE SPECIFICATIONS | DRFT | RWC | DATE | 08/20/08 |
| | | APVD | | SCALE | 1=1.0 |
| | FINISH SEE SPECIFICATIONS | ALL DIMENSIONS DISPLAYED ON THIS DRAWING ARE FOR REFERENCE ONLY | UNIT OF MEASUREMENT MILLIMETER [INCH] | | DESCRIPTION WK 4.43T-*--P7X2-WK 4.43T-P7X2 |
| DO NOT SCALE THIS DRAWING | | IDENTIFICATION NO. | | FILE:777016558 | SHEET 1 OF 1 |

| | | | | |
|-----|--------------------------------|-----|----------|---------|
| G | UPDATE CONTACT HOLDER ASSEMBLY | RDS | 05/03/12 | 37600 |
| REV | DESCRIPTION | BY | DATE | ECO NO. |