

SPECIFICATIONS	
OPERATING VOLTAGE	10-30 VDC
RIPPLE	≤10%
DIFFERENTIAL TRAVEL (HYSTERESIS)	1-15% (5% TYPICAL)
VOLTAGE DROP ACROSS CONDUCTING SENSOR	≤1.8 V at 150 mA
OUTPUT FUNCTION	NORMALLY OPEN 3-WIRE DC SELF-CONTAINED
TTL COMPATIBLE	NO
SHORT-CIRCUIT PROTECTED	YES
TRIGGER CURRENT FOR OVERLOAD PROTECTION	≥170 mA
CONTINUOUS LOAD CURRENT	≤150 mA
LEAKAGE (OFF-STATE) CURRENT	<10 μA
NO-LOAD CURRENT	5.5-9.5 mA
TIME DELAY BEFORE AVAILABILITY	≤8 ms
POWER-ON EFFECT PROTECTION	INCORPORATED
REVERSE POLARITY PROTECTION	INCORPORATED
WIRE-BREAK PROTECTION	INCORPORATED
PROTECTION AGAINST TRANSIENTS	1 kV, 0.1 ms, 1kΩ
OPERATING TEMPERATURE	-25°C to +70°C (-13°F to +158°F)
ENCLOSURE	MEETS NEMA 1, 3, 4, 6, 13 AND IEC IP67
SHOCK	30 g, 11 ms
VIBRATION	55 Hz, 1 mm AMPLITUDE (IN ALL 3 PLANES)
LED FUNCTION	YELLOW: OUTPUT ENERGIZED
RATED OPERATING DISTANCE(S _n)	2 mm = .079" (NOMINAL)
SWITCHING FREQUENCY	3000 Hz
REPEATABILITY	≤2% OF RATED OPERATING DISTANCE
SHIELDED	YES
MATING PLUGS/CABLES	4-PIN "EUROFAST" CONSTRUCTION

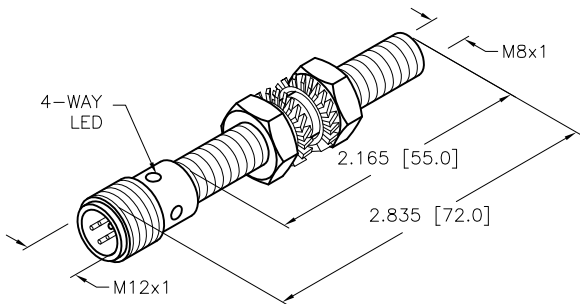

SOURCE DRAWING - FOR REFERENCE ONLY

RELATED DOCUMENTS 1. 2. 3. 4.	3RD ANGLE PROJECTION 	THIS DRAWING IS CONFIDENTIAL AND THE PROPERTY OF TURCK INC. USE OF THIS DOCUMENT WITHOUT WRITTEN PERMISSION IS PROHIBITED.		3000 CAMPUS DRIVE MINNEAPOLIS, MN 55441 1-800-544-7769 (763) 553-7300 (763) 553-0708 fax www.turck.us	
	MATERIAL STAINLESS STEEL BARREL	ALL DIMENSIONS DISPLAYED ON THIS DRAWING ARE FOR REFERENCE ONLY	DRFT GMB DATE 01/16/89	DESCRIPTION BI2-G08-AN6X-H1341	
	FINISH CHROME PLATED BRASS CONNECTOR		APVD SCALE 1=2.0	IDENTIFICATION NO. 46026	
	CONTACT TURCK FOR MORE INFORMATION		UNIT OF MEASUREMENT INCH [MILLIMETER]		REV E

E	UPDATE ID NUMBER PER HARMONIZATION PROJECT	CBM	01/30/18	
REV	DESCRIPTION	BY	DATE	ECO NO.

DO NOT SCALE THIS DRAWING

FILE: 46026

SHEET 1 OF 1