

SPECIFICATIONS	
CONTACT CARRIER MATERIAL	NYLON OR TPU
CONTACT MATERIAL/PLATING	BRASS/GOLD
HOUSING MATERIAL/PLATING	BRASS/NICKEL
RATED CURRENT [A]	1.5 A
RATED VOLTAGE [V]	36 VDC
TEMPERATURE RANGE	-40°C to +80°C (-40°F to +176°F)
PROTECTION CLASS	MEETS NEMA 1,3,4,6 AND IEC IP68
GASKET MATERIAL	NITRILE (BUNA N)
ISOLATOR MATERIAL	NYLON

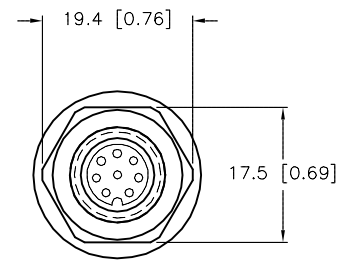
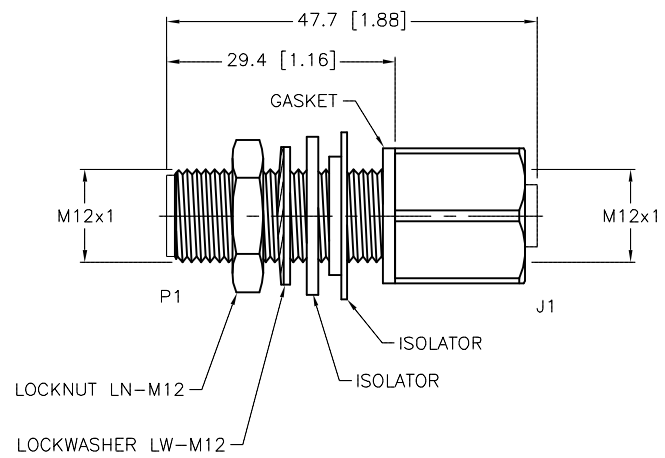
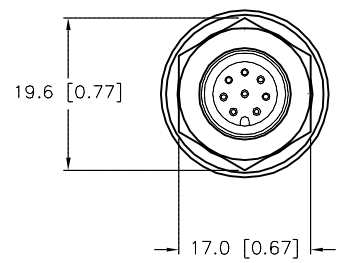
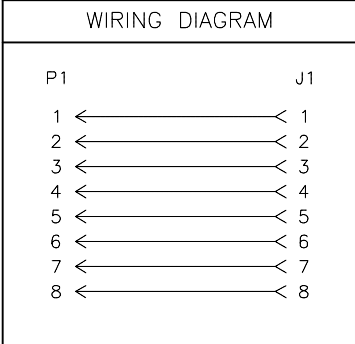

SOURCE DRAWING - FOR REFERENCE ONLY

NOTES:
1. CONNECTOR KEYWAY POSITIONS ARE REFERENCE ONLY. KEYWAYS MAY BE IN ANY POSITION.

RELATED DOCUMENTS 1. 2. 3. 4.	3RD ANGLE PROJECTION 	THIS DRAWING IS CONFIDENTIAL AND THE PROPERTY OF TURCK INC. USE OF THIS DOCUMENT WITHOUT WRITTEN PERMISSION IS PROHIBITED.		3000 CAMPUS DRIVE MINNEAPOLIS, MN 55441 1-800-544-7769 (763) 553-7300 (763) 553-0708 fax turck.com	
	MATERIAL SEE SPECIFICATIONS	ALL DIMENSIONS DISPLAYED ON THIS DRAWING ARE FOR REFERENCE ONLY	DRFT JBJ DATE 12/01/00	DESCRIPTION FK FS 8/M12	
	FINISH SEE SPECIFICATIONS		APVD SCALE 1=1.0		
	CONTACT TURCK FOR MORE INFORMATION		UNIT OF MEASUREMENT MILLIMETER [INCH]		IDENTIFICATION NO. U1135-3
DO NOT SCALE THIS DRAWING		FILE: U1135-3		SHEET 1 OF 1	

D	ADD KEYWAY NOTE	NF	06/15/15	49971
REV	DESCRIPTION	BY	DATE	ECO NO.