

Project	
Notes	
Type	Date
Cat. No.	

LSC™ Series **LED Surface Mount Canopy Luminaire**



DESCRIPTION

The Aleo LSC™ Series combines energy-efficiency, advanced optical control, and modern slim profile aesthetics to deliver enhanced performance to a range of surface-mount lighting applications. Rugged die-cast housing provides advanced thermal management for long life and weather-proof compartment to withstand challenging environments.

APPLICATIONS

Covered walkways, drive-thrus, semi-covered outdoor aisles, cold storage facilities or walk-in cooler/freezer, corridors, building canopies, large stairwells.

Specification Features



LSC Series
40W, 60W
120W

Construction

Rugged, die-cast housing with advanced thermal management system ensures reliability and durability. Weather-proof, gasketed driver compartment protects electronics against environmental elements.

Optical System

Precision-formed optical lens system improves safety and security by delivering high-efficiency illumination with precise optical distribution. Type VS distribution comes standard.

Certification

UL Listed. All components have UL certification.

Warranty

5-year Limited Warranty. See warranty documentation for more information.

Electrical

Luminaire utilizes high-efficacy LED packages maintained at cool temperatures for long life, high efficacy. Reliable driver features universal voltage (120-277V) for convenient installation.

Installation / Mounting

Luminaire comes standard with mounting plate for quick and easy installation.

Quick Ship
LSC-40/50K
LSC-60/50K
LSC-120/50K

Ordering Information

Example: LSC-40/50K

LSC	40	50K	[Blank]	[Blank]
Series	Nominal Wattage		Color Temp	
LSC	40	40W	50K	5000K
LED Surface	60	60W	Input Voltage	Finish Color
Mount Canopy	120	120W	Blank	Blank Dark Bronze
Luminaire			120V-277V	WH White
				BLK Black
				SLV Silver
				* Contact Factory for additional finish colors

Specifications and Dimensions subject to change without notice.

Performance Summary

Input Voltage	120V-277V
Input Frequency	50/60 Hz
Rated Wattage	See Performance Table
Delivered Lumens	See Performance Table
Efficacy	> 110 LPW (typ.)
CRI	70+, R9 > 0
Available CCT ¹	5000K
Rated Life	50,000 hours
Power Factor	> 0.9
THD	< 20%
IP Rating	IP66
Operating Temp.	-20°C to 50°C

Performance Data

Catalog No.	Rated Wattage (W)	Tested Wattage (W)	5000K	
			Delivered Lumens (lm)	Efficacy (lm/W)
LSC-40	43	43	5,047	116
LSC-60	55.6	56	6,709	120
LSC-120	121.6	122	14,604	120

Product Dimensions

LSC-40 | LSC-60

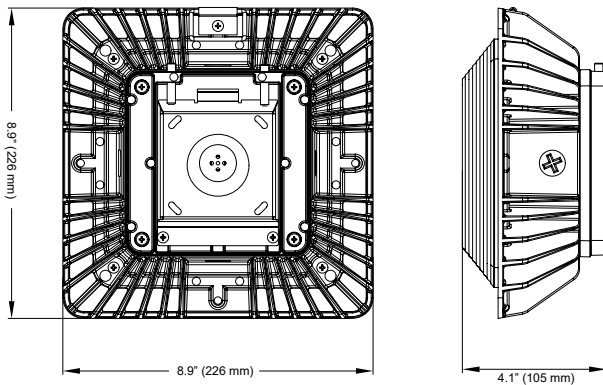

LSC-120

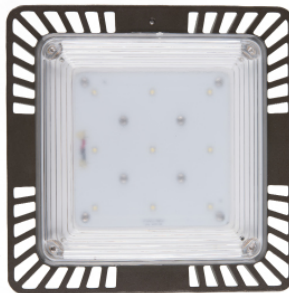
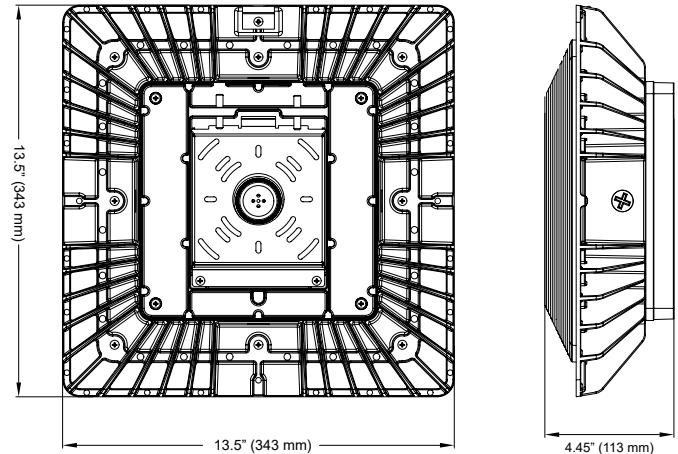

aleo™
LED LIGHTING

© 2017 Aleo Lighting, Inc. All rights reserved. For informational purposes only. Reproduction in whole or part is prohibited without prior written consent of the copyright owner. The information presented in this document does not form part of any quotation or contract, is believed to be accurate and reliable and may be changed without notice. No liability will be accepted by the publisher for any consequences of its use. Aleo Lighting reserves the rights make changes in specification at any time without notice.

Aleo Lighting, Inc.
www.aleoighting.com
13924 Bettencourt St.
Cerritos, CA 90703
Ph: 877-358-8825

Specifications and Dimensions subject to change without notice.