

Safety Limit Switches Type: HLM (Die-Cast)

APPLICATIONS:

IDEM's HLM range of heavy duty Die Cast Safety Limit Switches have been designed to be mounted for position sensing of moving applications e.g. guard doors, conveyors, machine beds and elevators. They are available with an extensive range of actuator heads and can be supplied with either slow break or snap action contacts.



FEATURES:

- Heavy duty die cast bodies (painted red)
- Positive opening NC safety contact to EN60947-5-1
- High mechanical life over 5,000,000 cycles
- Industry standard mounting to EN50041
- Large choice of actuator heads available

OPERATION:

Operation of IDEM Safety Limit Switches is achieved by a sliding actuation of the moving object to cause deflection of the switch plungers, rollers or levers.

For safety applications it is important that the moving object does not pass completely over the switch actuators so as to either cause damage to the actuator or allow it to return to its original position.



HLM-RP

HLM-SRL

HLM-PP

HLM-AL

HLM-ARL

HLM-SL

HLM-TSL

CONTACT BLOCKS:

Contact blocks provide positively operated safety contacts to EN60947-5-1 with optional Explosion Proof versions available.

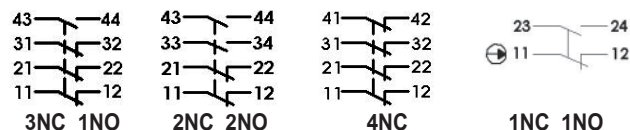

EXPLOSION PROOF MODELS ALSO AVAILABLE.
SEE MODELS/PART NUMBERS MARKED WITH EX

TECHNICAL SPECIFICATIONS:

Standards: ISO14119 EN60947-5-1 EN60204-1
ISO13849-1 EN62061 UL508

Safety Classification and Reliability Data:

Mechanical Reliability B10d	2.5x10 ⁶ operations at 100mA load
ISO13849-1	Up to PLe depending upon system architecture
EN62061	Up to SIL3 depending upon system architecture
Safety Data - Annual Usage	8 cycles per hour/24 hours per day/365 days
	MTTFd 356 years
Positive Opening Operation	NC contacts
Utilisation Category	AC15 A300 240V 3A
Minimum Current	5V 5mA dc
Thermal Current (Ith)	10A
Rated Insulation Voltage	300Vac
Rated Impulse Withstand	2500Vac
Maximum Switching Speed	250mm/sec
Maximum Switching Frequency	6,000 operations per hour
Case Material	Die cast metal - painted red
Enclosure Protection	IP67
Operating Temperature	-25C to +80C
Mechanical Life Expectancy	5x10 ⁶ cycle min.
Electrical Life Expectancy	100,000 cycle min (at full load)
Vibration	IEC68-2-6 10-55Hz 0.35mm
Conductor Size	1.5mm ²
Fixing	M5 bolts

EX CLASSIFICATION:

- Exd IIC T6 (-20 ≤ Ta ≤ +60C) Gb
- Ex tb IIIC T85C (-20 ≤ Ta ≤ +60C) Db

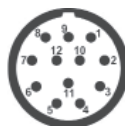

Quick Connect (QC) M23 12 Way Male (connector length 26mm) (pin view from switch)	Switch Circuit
1 3	11/12
4 6	21/22
7 8	33/34 or 31/32
9 10	41/42 or 43/44
12	Earth

Safety Limit Switches Type: HLM (Die-Cast)

HLM SHORT ROLLER LEVER:

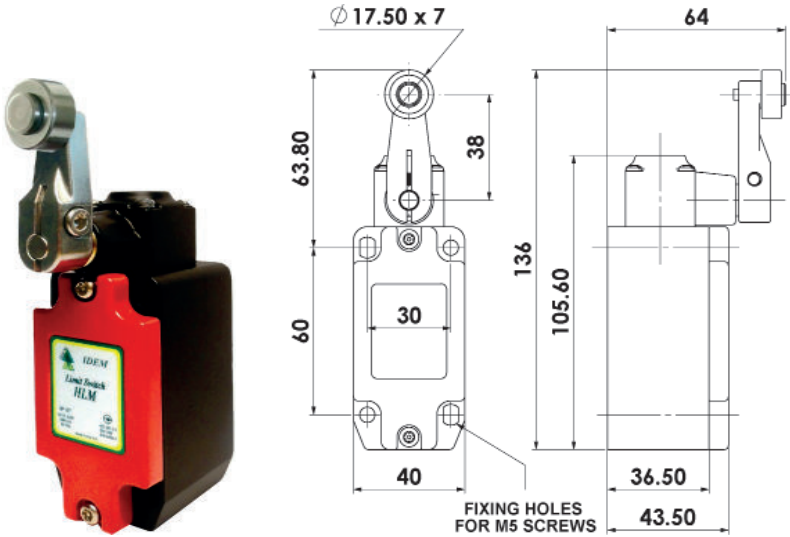

HLM SHORT ROLLER LEVER	SALES NUMBERS		
	M20	1/2"NPT	QC M23
2NC 2NO	174001	174002	174003
3NC 1NO	174004	174005	174006
4NC	174007	174008	174009
1NC 1NO Snap	174010	174011	174012
1NC 1NO EX	174013	3m 4 core Ex	
2NC EX	174014	3m 4 core Ex	
2NC 2NO EX	174015	3m 8 core Ex	

Gold Plated Contacts available for low power circuits (5V 5mA).
Ordering: Add GC to Part Number e.g. 174001-GC

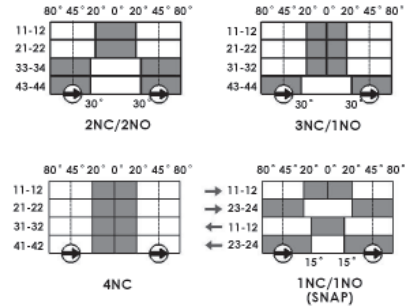

HLM ROLLER PLUNGER:

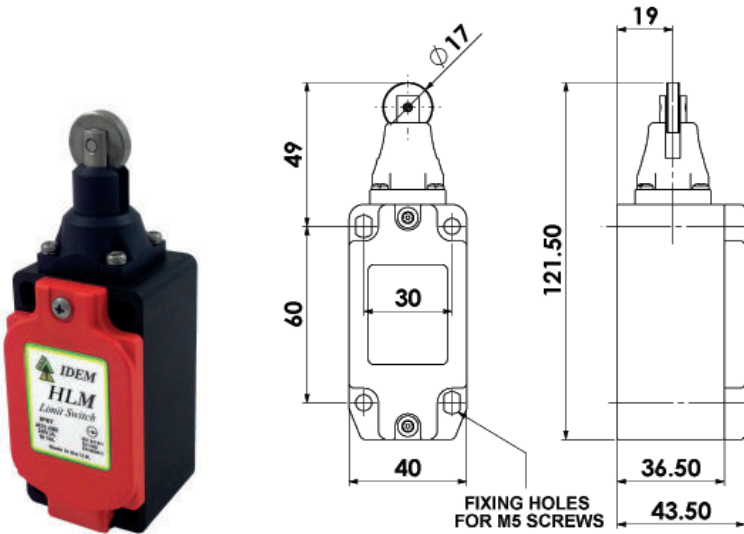

HLM ROLLER PLUNGER	SALES NUMBERS		
	M20	1/2"NPT	QC M23
2NC 2NO	174051	174052	174053
3NC 1NO	174054	174055	174056
4NC	174057	174058	174059
1NC 1NO Snap	174060	174061	174062
1NC 1NO EX	174063	3m 4 core Ex	
2NC EX	174064	3m 4 core Ex	
2NC 2NO EX	174065	3m 8 core Ex	

Gold Plated Contacts available for low power circuits (5V 5mA).
Ordering: Add GC to Part Number e.g. 174051-GC

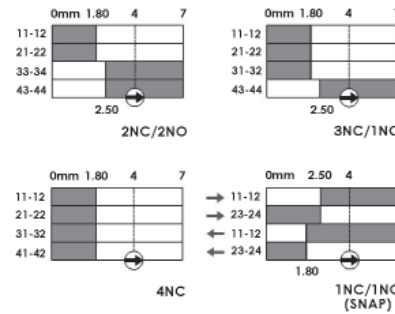

HLM PIN PLUNGER:

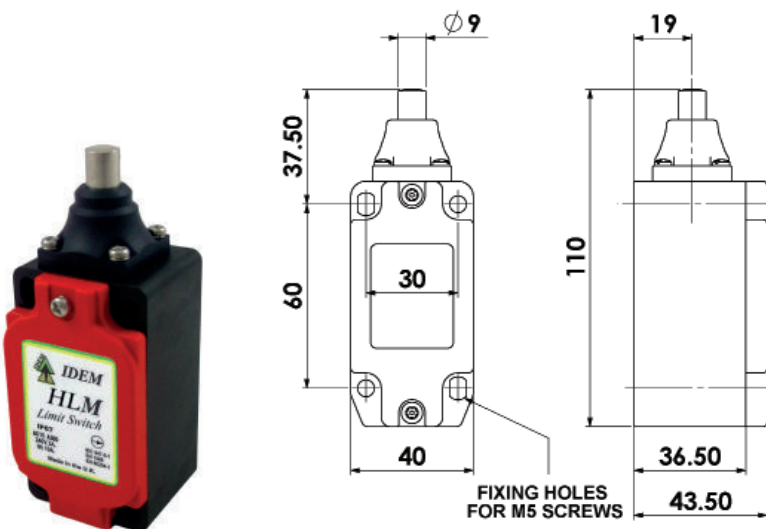

HLM PIN PLUNGER	SALES NUMBERS		
	M20	1/2"NPT	QC M23
2NC 2NO	174101	174102	174103
3NC 1NO	174104	174105	174106
4NC	174107	174108	174109
1NC 1NO Snap	174110	174111	174112
1NC 1NO EX	174113	3m 4 core Ex	
2NC EX	174114	3m 4 core Ex	
2NC 2NO EX	174115	3m 8 core Ex	

Gold Plated Contacts available for low power circuits (5V 5mA).
Ordering: Add GC to Part Number e.g. 174101-GC

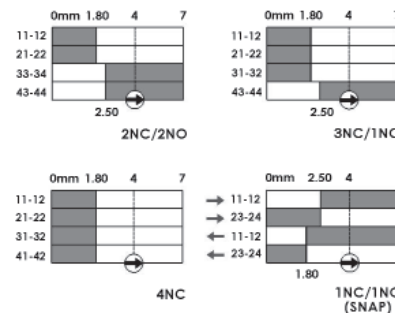

Safety Limit Switches Type: HLM (Die-Cast)

HLM SPRING LEVER:

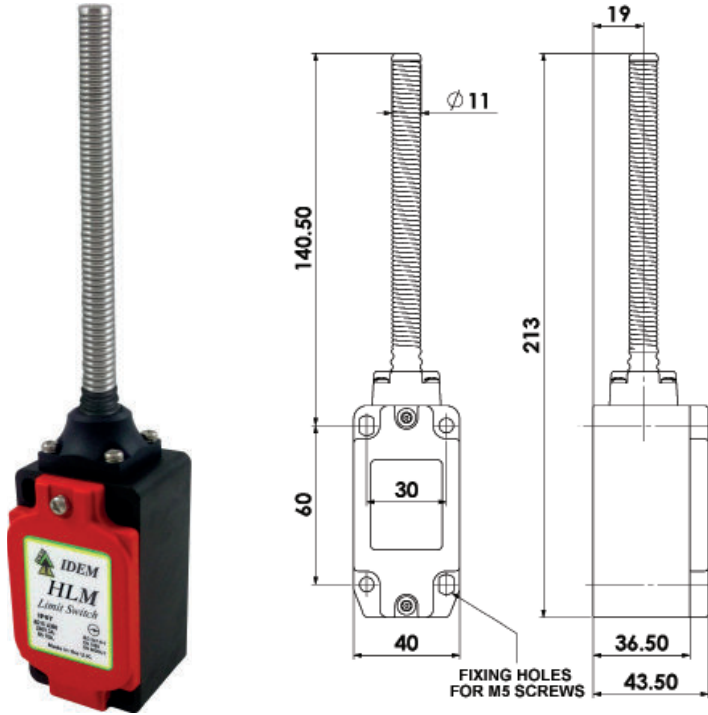

HLM SPRING LEVER	SALES NUMBERS		
	M20	1/2"NPT	QC M23
2NC 2NO	174151	174152	174153
3NC 1NO	174154	174155	174156
4NC	174157	174158	174159
1NC 1NO Snap	174160	174161	174162
1NC 1NO EX	174163	3m 4 core Ex	
2NC EX	174164	3m 4 core Ex	
2NC 2NO EX	174165	3m 8 core Ex	

Gold Plated Contacts available for low power circuits (5V 5mA).
Ordering: Add GC to Part Number e.g. 174151-GC

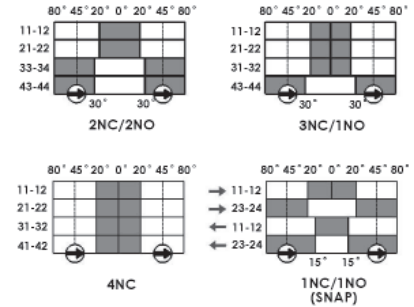

HLM TELESCOPIC SPRING LEVER:

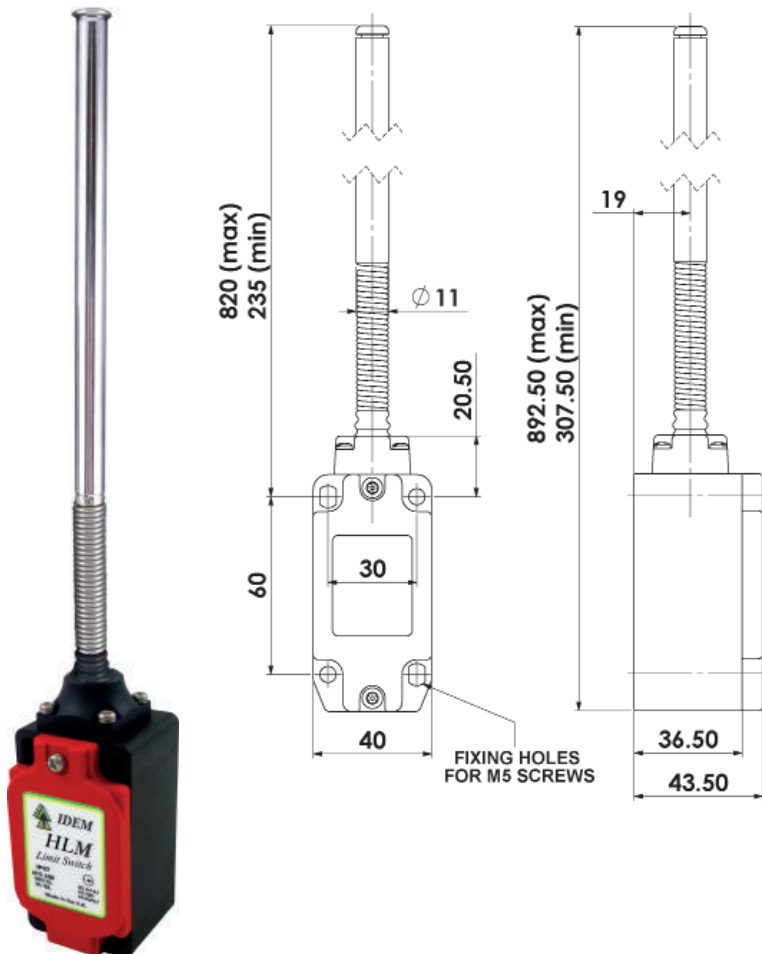

HLM TELESCOPIC SPRING LEVER	SALES NUMBERS		
	M20	1/2"NPT	QC M23
2NC 2NO	174201	174202	174203
3NC 1NO	174204	174205	174206
4NC	174207	174208	174209
1NC 1NO Snap	174210	174211	174212
1NC 1NO EX	174213	3m 4 core Ex	
2NC EX	174214	3m 4 core Ex	
2NC 2NO EX	174215	3m 8 core Ex	

Gold Plated Contacts available for low power circuits (5V 5mA).
Ordering: Add GC to Part Number e.g. 174201-GC

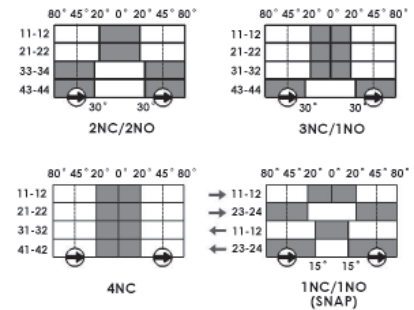

Safety Limit Switches Type: HLM (Die-Cast)

HLM LEVER ARM

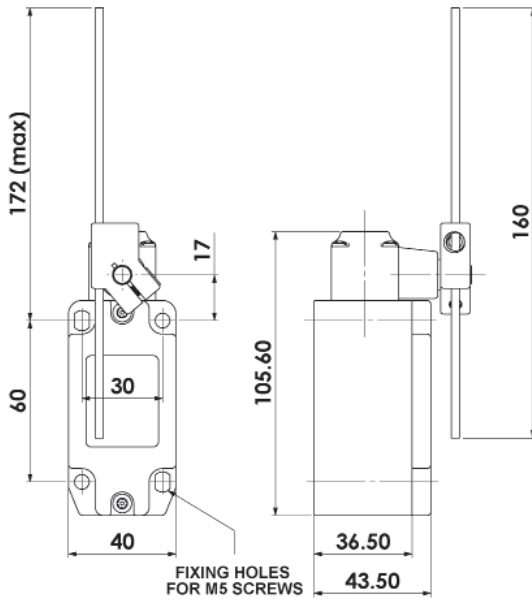

HLM LEVER ARM	SALES NUMBERS		
	M20	1/2"NPT	QC M23
2NC 2NO	174251	174252	174253
3NC 1NO	174254	174255	174256
4NC	174257	174258	174259
1NC 1NO Snap	174260	174261	174262
1NC 1NO EX	174263	3m 4 core Ex	
2NC EX	174264	3m 4 core Ex	
2NC 2NO EX	174265	3m 8 core Ex	

Gold Plated Contacts available for low power circuits (5V 5mA).
Ordering: Add GC to Part Number e.g. 174151-GC

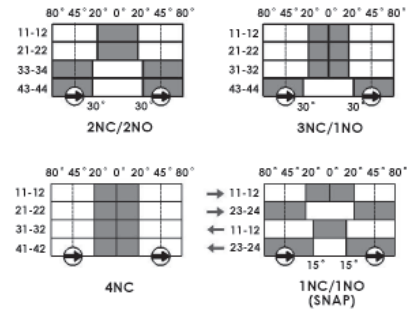

HLM ADJUSTABLE ROLLER LEVER:

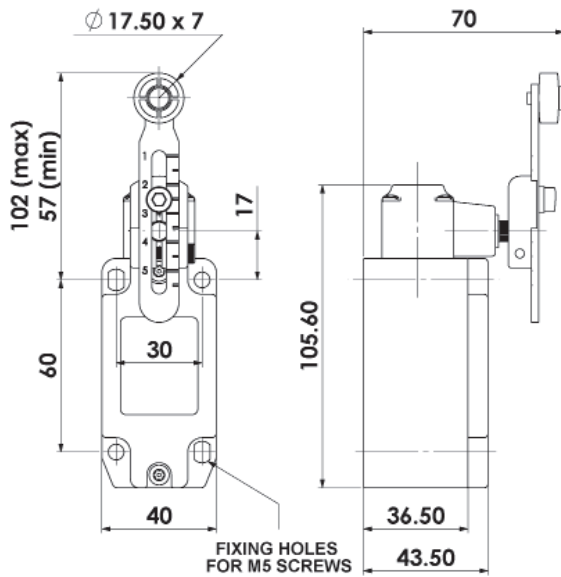

HLM ADJUSTABLE ROLLER LEVER	SALES NUMBERS		
	M20	1/2"NPT	QC M23
2NC 2NO	174301	174302	174303
3NC 1NO	174304	174305	174306
4NC	174307	174308	174309
1NC 1NO Snap	174310	174311	174312
1NC 1NO EX	174313	3m 4 core Ex	
2NC EX	174314	3m 4 core Ex	
2NC 2NO EX	174315	3m 8 core Ex	

Gold Plated Contacts available for low power circuits (5V 5mA).
Ordering: Add GC to Part Number e.g. 174201-GC

