

FS1A Multi-function Safety Relay

Key features:







- No programming required. Configuration complete by turning on a logic switch
- A safety circuit can be configured easily just by selecting a logic from eight pre-programmed logics
- Mode selection, partial/entire stop can be achieved just by selecting a logic
- One SafetyOne module can connect with various safety inputs such as emergency stop switches and light curtains
- The status of safety I/Os and the SafetyOne errors can be monitored
- Solenoid drive output is provided, eliminating the need for a PLC
- IEC 61508 safety integrity level 3, ISO 13849-1 performance level e, and EN954-1 control category 4 compliant



Part Numbers

No. of Logic	Part Number
8	FS1A-C01S
24	FS1A-C11S

Optional Parts

Product	Part Number	Note
Input Connector 	FS9Z-CN01	
Output Connector 	FS9Z-CN02	
Connecting Tool 	FS9Z-SD01	
Marked Cable Tie 	FS9Z-MT01	Used to lock the protective cover of the FS1A.
DIN Rail 	BNDN1000	Aluminum, 1m 35mm wide
End Clip 	BNL6	

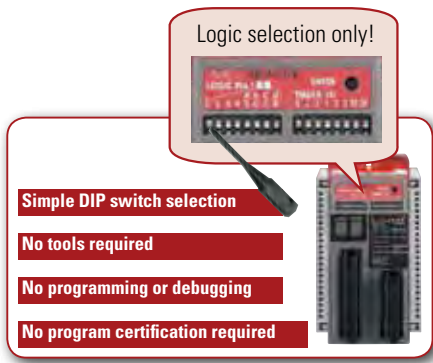

Complies with key safety standards!



The SafetyOne satisfies:

EN 954-1	Category 4	ISO	IEC	EN	ANSI/RIA
IEC 61508	SIL3	ANSI	SEMI	NFPA	
ISO 13849-1	Performance level e				

With 8 (FS1A-C01S) or 24 (FS1A-C11S) pre-programmed safety circuit logics in a compact housing, the FS1A SafetyOne safety controller allows you to build a safety circuit by just sliding a DIP switch. Because the programs are tested and approved for compliance with key safety standards, labor, cost, and time for safety system certification can be reduced greatly.



Note: The eight logic programs of FS1A-C01S are not included in the 24 logic programs of FS1A-C11S.

Overview

XW Series E-Stops

Interlock Switches

Enabling Switches

Safety Control

Light Curtains

AS-Interface Safety at Work

Large functionality in a compact housing!

Small & Compact

ALL-IN-ONE

Replaces more than seven safety relay modules

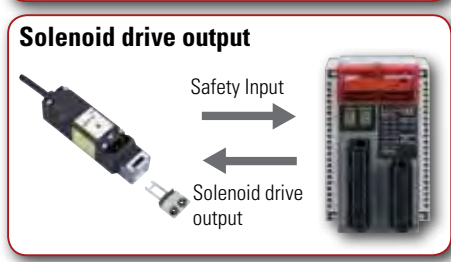
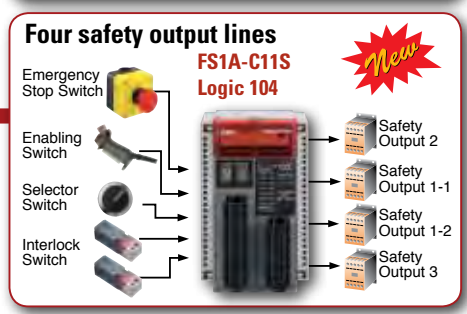
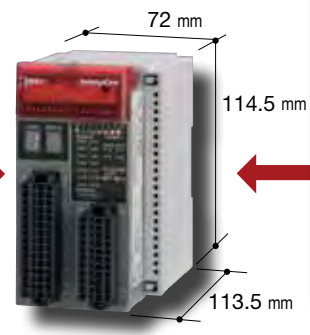
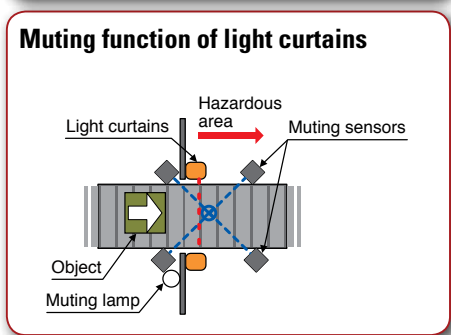
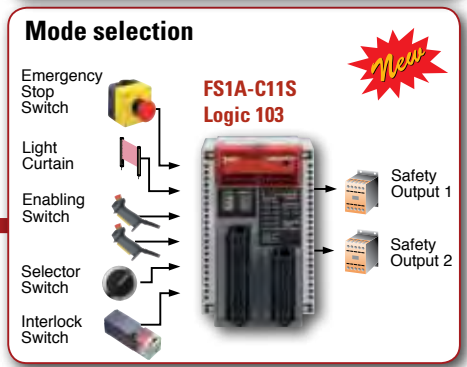
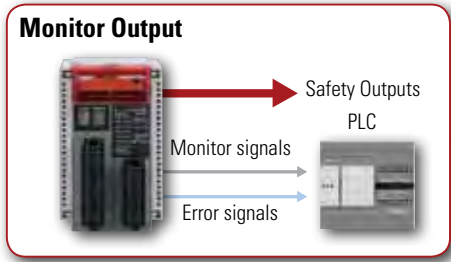
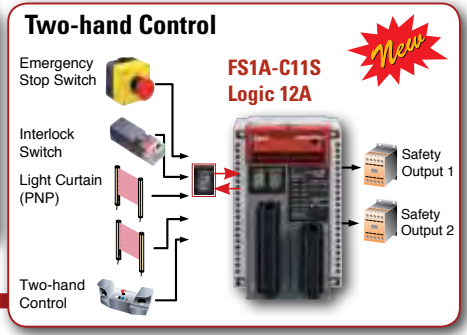

Overview

XW Series E-Stops

Interlock Switches

Enabling Switches

Safety Control

Light Curtains

AS-Interface Safety at Work

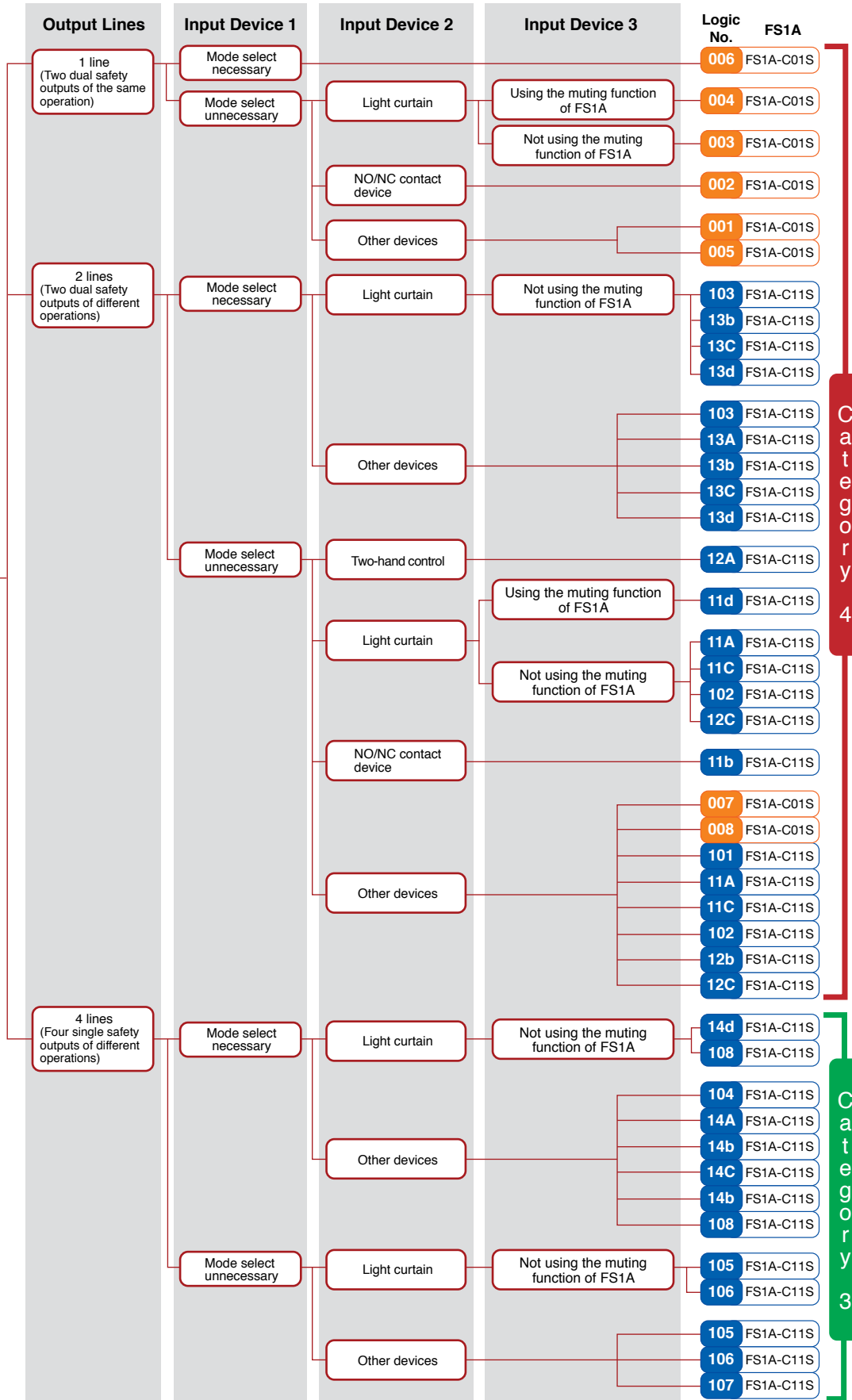

Category 4

Category 3

Specifications

Operating Environment

Applicable Standards	TÜV approval: IEC/EN 61000-6-2, IEC/EN 61000-6-4, IEC/EN 61496-1, IEC 61508 Part 1-7, IEC/EN 62061, ISO 13849-1, ISO 13851 (FS1A-C11S), EN 954-1 UL: UL508, CSA C22.2 No. 142 Applicable standards: IEC/EN 60204-1, IEC/EN 61131-2, ISO 10218-1, ANSI/RIA R15.06, ANSI B11.19, SEMI S2-0706, NFPA79 EN 954-1, 13849-1, 62061, 61496-1, 60204-1, 61131-2, 61000-6-2, 61000-6-4 ANSI/RIA R15.06 ANSI B11.19 SEMI S2 NFPA 79
Safety Circuit	Logic selection
Operating Temperature	-10 to +55°C (no freezing)
Operating Humidity	10 to 95% RH (no condensation)
Storage Temperature	-40 to +70°C (no freezing)
Storage Humidity	10 to 95% RH (no condensation)
Pollution Degree	2 (IEC/EN60664-1)
Degree of Protection	IP20 (IEC/EN60529)
Corrosion Immunity	Free from corrosive gases
Altitude	Operation: 0 to 2000m, Transport: 0 to 3000m
Vibration Resistance	Vibration: 5 to 8.4 Hz, amplitude 3.5 mm 8.4 to 150 Hz Acceleration: 9.8 m/s ² (2 hours each on three mutually perpendicular axes) (IEC/EN60028-2-6) Bump: Acceleration 98 m/s ² , 16 ms (1000 times each on three mutually perpendicular axes) (IEC/EN60028-2-29)
Shock Resistance	147 m/s ² , 11ms (3 shocks each on three mutually perpendicular axes (IEC/EN 60028-2-27)
Connector Insertion/Removal Durability	50 times maximum
Configuration Switch Durability	100 operations maximum per pole
Enter Button Durability	1000 operations maximum
Housing Material	Modified-polyphenyleneether (m-PPE)
Weight (approx.)	330g

Electric Characteristics

Rated Voltage	24V DC
Allowable Voltage Range	20.4 to 28.8V DC
Maximum Power Consumption	48W (at the rated power voltage, when all I/Os are ON) (incl. output load)
Allowable Momentary Power Interruption	10 ms minimum (at the rated power voltage)
Response Time	ON-OFF: 40 ms maximum ¹ 100 ms maximum ² OFF-ON: 100 ms maximum ³
Start-up Time ⁴	6 sec maximum
Dielectric Strength	Between live part and FE terminal: 500V AC, 1 minute Between housing and FE terminal: 500V AC, 1 minute
Insulation Resistance	Between live part and FE terminal: 10 MΩ minimum (500V DC megger) Between housing and FE terminal: 10 MΩ minimum (500V DC megger)
Impulse Noise Immunity (noise simulator)	Power terminal: ±1 kV 50 ns, 1μs (direct connection) I/O terminal: ±2kV 50 ns, 1μs (coupling adapter)
Inrush Current	25A maximum
Ground	Ground resistance of 100Ω maximum
Effect of Incorrect Wiring	Reverse polarity: No operation, no damage Improper voltage: Permanent damage may occur



1. The time to shut off safety outputs after inputs are turned off or input monitor error is detected (when off-delay timer is set to 0s)
2. Time to shut off safety outputs after an error (except input monitor error) or a configuration change of logic or timer is detected (not depending on the off-delay timer value)
3. Auto start—Time to turn on safety outputs after safe inputs are turned on
Manual start—Time to turn on safety outputs after start inputs are turned on
Control start—Time to turn on safety outputs after the start inputs are turned off-on-off (maintain ON for 0.1 to 5s)
4. Time to change to Run state after power supply is turned on.

Overview

XW Series E-Stops

Interlock Switches

Enabling Switches

Safety Control

Light Curtains

AS-Interface Safety at Work

Examples

Overview

FS1A-C11S Logic 105	Partial stop logic for apparatus with openings	Output Line: 4 4 single safety outputs of different operations	Category 3
------------------------	--	---	---------------

Logic 105 is used for safeguarding measures of machine tools and robots, which use safety equipment such as light curtains with dual solid state outputs. Safety outputs are single output. Five dual channel safety inputs can be connected. Safety output 4 has an off-delay timer.

Wiring Example

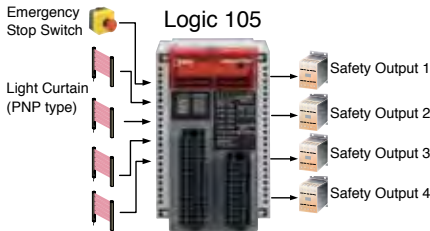

Logic Chart

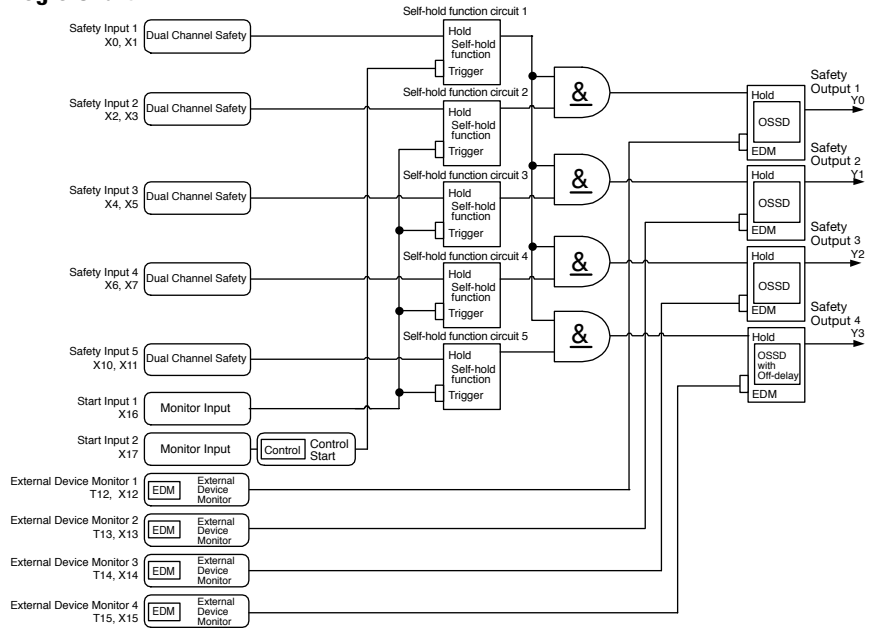

XW Series E-Stops

DIP Switch and LED Display



Interlock Switches

Enabling Switches

FS1A-C11S Logic 13b	The logic constructing an OR circuit applicable for selection of active safety input devices	Output Line: 2 2 dual safety outputs of different operations	Category 4
------------------------	--	---	---------------

In machine tools and robots, a hazard source is isolated by a guard in automatic operation. In human-attended operation such as teaching and maintenance, the operator has to work inside a hazardous area. Logic 13b is used to configure a system in which teach or auto mode can be selected using a selector switch. Safety outputs are dual channel outputs. OR circuit can be configured in auto mode. Two dual channel direct opening input, one mode select input, one dual channel dependent input, and two dual channel safety inputs can be connected. Safety output 2 has an off-delay timer.

Wiring Example

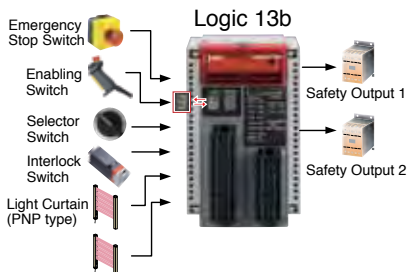

Logic Chart

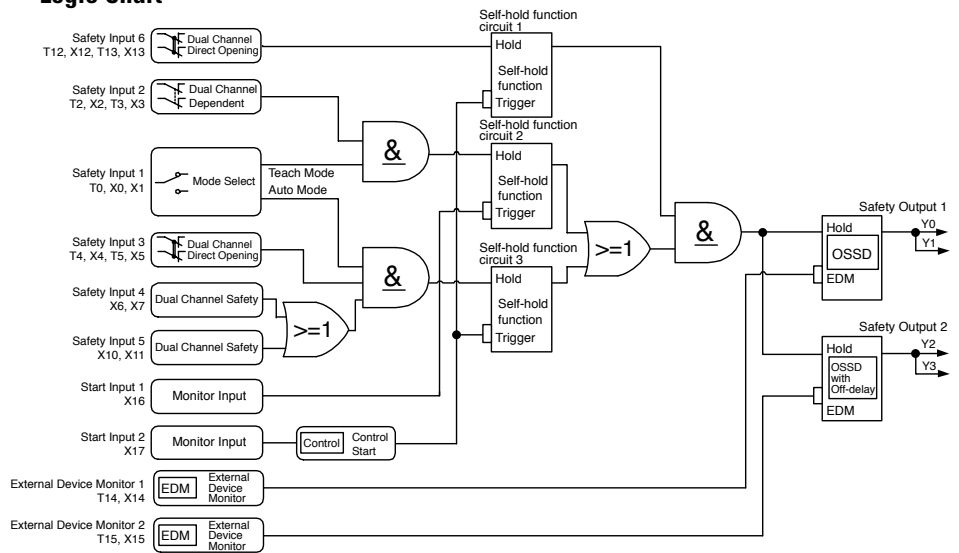

DIP Switch and LED Display



Light Curtains

AS-Interface Safety at Work

FS1A-C11S Logic 13C	Partial stop logic applicable for selection of active safety input devices	Output Line: 2 2 dual safety outputs of different operations	Category 4
------------------------	--	---	------------

In machine tools and robots, a hazard source is isolated by a guard in automatic operation. In human-attended operation such as teaching and maintenance, the operator has to work inside a hazardous area. Logic 13C is used to configure a system in which teach or auto mode can be selected using a selector switch. Safety outputs are dual channel outputs. Three dual channel direct opening inputs, one mode select input, one dual channel dependent input, one dual channel safety input can be connected. Safety output 2 has an off-delay timer.

Wiring Example

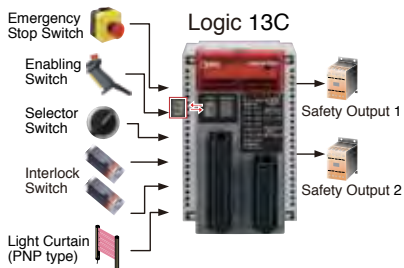

Logic Chart

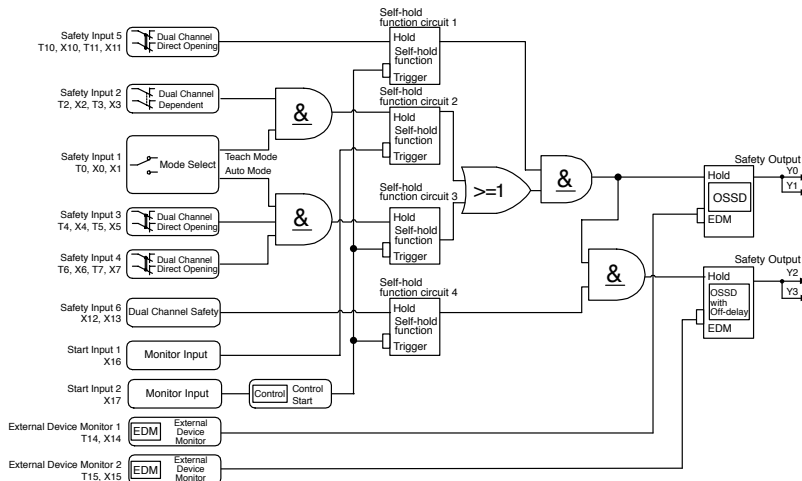

DIP Switch and LED Display

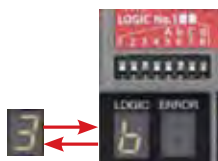

FS1A-C11S Logic 12A	The logic for apparatus with a two-hand control device	Output Line: 2 2 dual safety outputs of different operations	Category 4
------------------------	--	---	------------

Logic 12A is used for safeguarding measures of machine tools that use two-hand control. Safety outputs are dual channel outputs. Two dual channel direct opening inputs, one two-hand control input (two safety inputs = one point), and two dual channel safety inputs can be connected. Safety output 2 has an off-delay timer.

Wiring Example

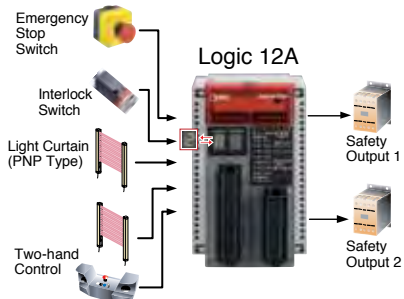

Logic Chart

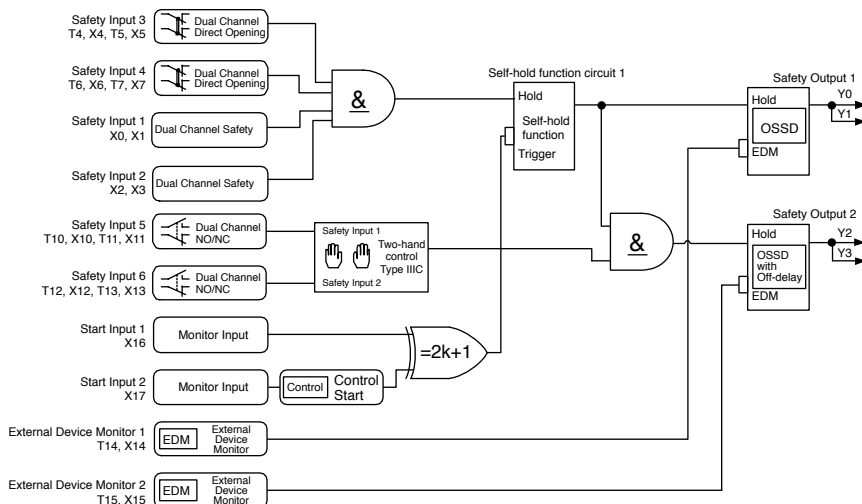

DIP Switch and LED Display



FS1A-C01S Logic 004	Muting function logic for apparatus with openings	Output Line: 1 2 dual safety outputs of the same operation	Category 4
------------------------	---	---	---------------

In Logic 004, muting functions are added to the dual solid state output of Logic 003. Dual direct-opening components such as emergency stop switches and interlock switches can be used at the same time.

Muting Function Improves Productivity

With a muting function, the system stops when detecting a human and temporarily defeats the light curtain while work objects are being supplied. This improves the system's productivity. Muting functions can be used easily by connecting a light curtain, muting sensor, and muting lamp to the SafetyOne (Note). In muting status, the OFF signals of corresponding safety solid state outputs are defeated.

Wiring Example

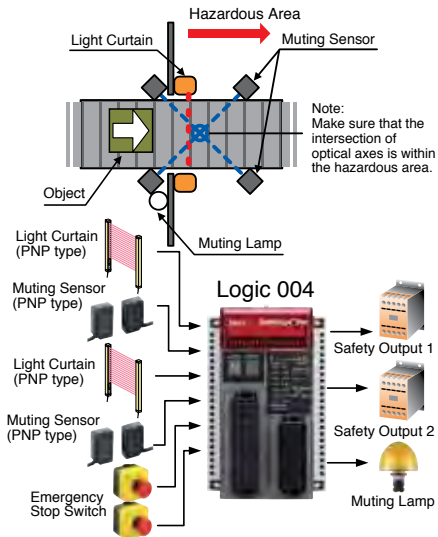

Logic Chart

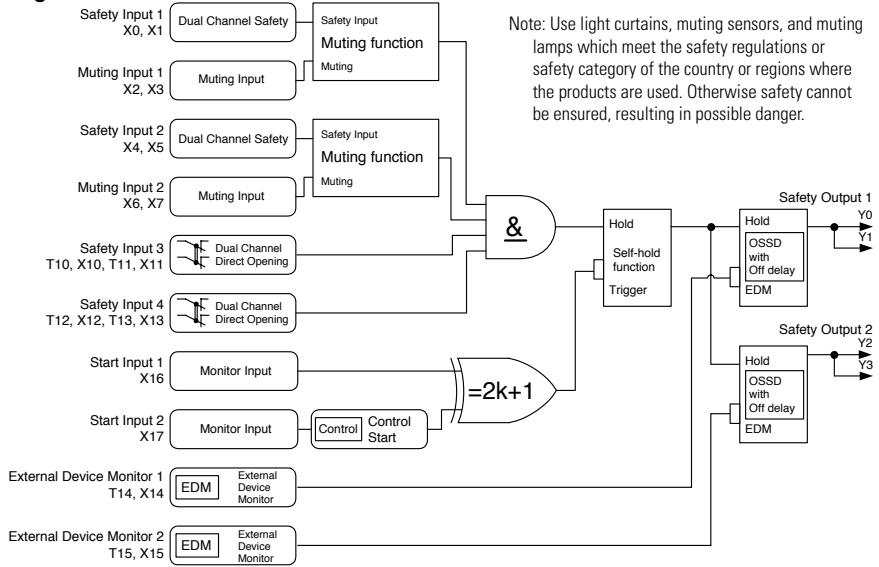

Note: When installing light curtain and muting sensor, ensure safety by referring to IEC TS 62046 technical documents.

DIP Switch and LED Display



Safety Input Specifications

Drive Terminals

(T0, T1, T2, T3, T4, T5, T6, T7, T10, T11, T12, T13, T14, T15)

Rated Drive Voltage	Power supply voltage
Minimum Drive Voltage	Power supply voltage – 2.0V
Number of Drive Terminals	14
Maximum Drive Current	20 mA per terminal (28.8V DC) (Note)

Note: Drive terminals of safety inputs send safety confirmation signals (pulse signals) for the diagnosis of safety components and input circuits.

Wiring and diagnosis function change depending on the selected logic. See user's manual "Chapter 5 Logic." Basic specifications remain the same.

Receive Terminals

(X0, X1, X2, X3, X4, X5, X6, X7, X10, X11, X12, X13, X14, X15)

Rated Input Voltage	24V DC
Input ON Voltage	15.0 to 28.8V DC
Input OFF Voltage	Open or 0 to 5.0V DC
Number of Inputs	14
Input Current	10 mA per terminal (at the rated power voltage)
Input Signal	Sink input (for PNP output), Type 1 (IEC61131-2)

Wire

Cable Length (Note)	100m maximum (total wire length per input)
Allowable Wire Resistance	300Ω maximum

Note: When wiring between the SafetyOne and a component is 30m or more, use shielded cable to ensure electromagnetic immunity.

• Receive Terminal Internal Circuit

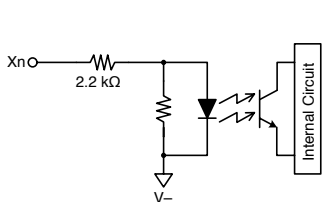

• Receive Terminal Operating Range

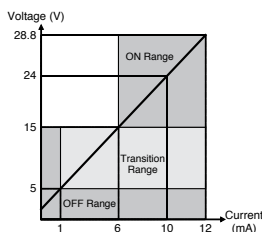

Start Input Specifications

Rated Input Voltage	24V DC
Input ON Voltage	15.0 to 28.8V DC
Input OFF Voltage	Open or 0V to 5.0V DC
Number of Start Inputs	2 (X16, X17)
Input Current	5 mA per terminal (at the rated power voltage)
Input Signal	Sink input (PNP output), Type 1 (IEC61131-2)
Cable Length (Note)	100m maximum (total wire length per input)
Allowable Wire Resistance	300Ω maximum

Note: When wiring between the SafetyOne and a component is 30m or more, use shielded cable to ensure electromagnetic immunity.

• Start Input Internal Circuit

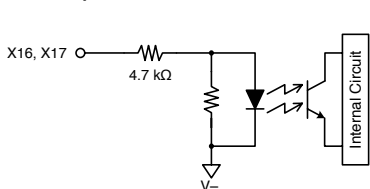

• Start Input Operation Range

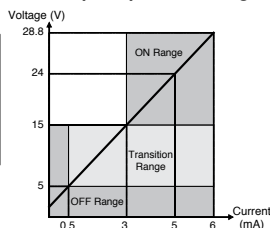

Safety Output Specifications

Output Type	Source output (N channel MOSFET)	
Rated Output Voltage	Power supply voltage	
Minimum Output Voltage	Power supply voltage – 2.0V	
Number of Safety Outputs	4 (Y0, Y1, Y2, Y3)	
Maximum Output Current	1 output	500 mA maximum
	Total	1A maximum
Leakage Current	0.1 mA maximum	
Allowable Inductive Load ¹	L/R = 25 ms	
Allowable Capacitive Load	1 μF maximum	
Cable Length ²	100m maximum (total length per output)	

1. When connecting an inductive load, connect a protection element such as a diode.

2. When wiring between the SafetyOne and a component is 30m or more, use shielded cable to ensure electromagnetic immunity.

• Safety Output Internal Circuit

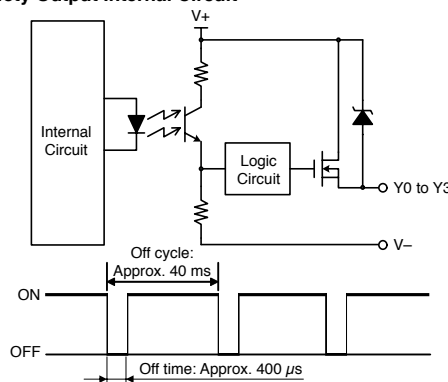

The safety outputs of the SafetyOne are solid state outputs. When the output is on, off-check signals are generated at regular intervals. The operating characteristics of the safety output change depending on the selected logic. For details, see user's manual "Chapter 5 Logic." The basic specifications remain the same.

Note that off-check signals may cause reaction of some safety components depending on their response speed. Monitor output and solenoid/lamp output do not generate outputs of off-check signals.

Monitor Output Specifications

Output Type	Source output (N channel MOSFET)	
Rated Output Voltage	Power supply voltage	
Minimum Output Voltage	Power supply voltage – 2.0V	
Number of Safety Outputs	4 (Y0, Y1, Y2, Y3)	
Maximum Output Current	1 output	500 mA maximum
	Total	1A maximum
Leakage Current	0.1 mA maximum	
Allowable Inductive Load ¹	L/R = 25 ms	
Allowable Capacitive Load	1 μF maximum	
Cable Length ²	100m maximum (total length per output)	

Note: When wiring between the SafetyOne and a component is 30m or more, use shielded cable to ensure electromagnetic immunity.

• Monitor Output Internal Circuit

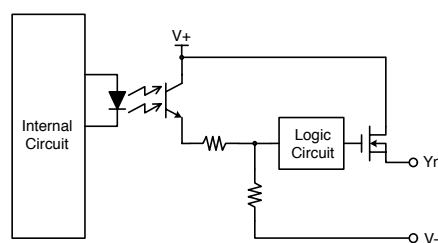

The operating characteristics of the monitor output change depending on the selected logic. For details, see user's manual "Chapter 5 Logic." The basic specifications remain the same.

Do not use monitor output as a safety output, otherwise the system's safety cannot be assured when the SafetyOne or safety components fail.

Solenoid/Lamp Output Specifications

Output Type	Source output (N channel MOSFET)	
Rated Output Voltage	Power supply voltage	
Minimum Output Voltage	Power supply voltage – 2.0V	
No. of Solenoid/Lamp Outputs	2 (Y17, Y20)	
Maximum Output Current	1 output	500 mA maximum
	Total	500 mA maximum
Leakage Current	0.1 mA maximum	
Allowable Inductive Load ¹	L/R = 25 ms	
Cable Length ²	100m maximum (total length per output)	

1. When connecting an inductive load, connect a protection element such as a diode.
2. When wiring between the SafetyOne and a component is 30m or more, use shielded cable to ensure electromagnetic immunity.

Solenoid/Lamp Output Internal Circuit

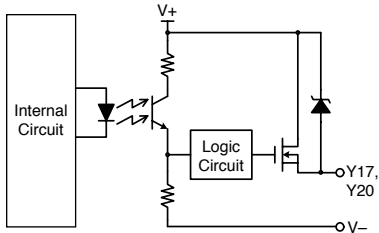

The selected operating characteristics of solenoid/lamp output change depending on the selected logic. For details, see user's manual "Chapter 5 Logic." The basic specifications remain the same. Do not use solenoid/lamp output as a safety output, otherwise the system's safety cannot be assured when the SafetyOne or safety components fail.

Internal States

State	Description
Initial	Initial processing is performed immediately after power is supplied to the SafetyOne. The internal circuits are checked and the LEDs show operation confirmation (blinking) for 6 seconds (approx).
Run	The SafetyOne is under normal operation. Logic processing continues without failures or wiring errors.
Configuration	A logic or off-delay timer value is being configured. Configuration enables the logic and off-delay timer value. When completed, the SafetyOne changes to the Run state.
Protection	An input monitor error has occurred with dual channel input, EDM input, or muting input. When the problem is removed, the SafetyOne changes to Run state.
Stop	A failure or error has occurred with an external device or internal circuit. When the problem is removed and the power is turned on, Stop state is cleared.

LED and Output States

When safety outputs are dual channel outputs

State	Logic LED	Error LED	Timer LED	Safety Output		Monitor Output			
				Y0 to Y3	Solenoid/Lamp Output Y17, Y20	Y4 to Y13	Y14	Y15	Y16
Initial	(Note 1)	(Note 1)	(Note 1)	OFF	OFF	OFF	ON	ON	OFF
Run	Logic #	Blank	Selected Value	(Note 2)	(Note 2)	(Note 2)	OFF	OFF	ON
Configuration	(Note 3)	C	(Note 3)	OFF	OFF	OFF	OFF	ON	OFF
Protection	Logic #	1	Selected Value	Off (Note 6)	OFF	(Note 4)	OFF	ON	OFF
Stop	Blank	(Note 5)	Blank	OFF	OFF	(Note 4)	ON	ON or OFF	OFF

When safety outputs are single channel outputs

State	Logic LED	Error LED	Timer LED	Safety Output		Monitor Output			
				Y0 to Y3	Y4 to Y13, Y17, Y20	Y14	Y15	Y16	
Initial	(Note 1)	(Note 1)	(Note 1)	OFF	OFF	ON	ON	OFF	
Run	Logic #	Blank	Selected Value	(Note 2)	(Note 2)	OFF	OFF	ON	
Configuration	(Note 3)	C	(Note 3)	OFF	OFF	OFF	ON	OFF	
Protection	Logic #	1	Selected Value	Off (Note 6)	(Note 4)	OFF	ON	OFF	
Stop	Blank	(Note 5)	Blank	OFF	(Note 4)	ON	ON or OFF	OFF	

1. Random display of Initial state.
 2. Output and LED display of the selected logic.
 3. Blinking LED display of the selected logic number or the selected timer value.
 4. Pulsing display of monitor output and output LED corresponding to the input of error. Other LEDs and monitor outputs maintain the display of Run state.
 5. Error number is displayed.
 6. Safety output with timer is turned OFF after set OFF-delay time.
- Caution: Solenoid/lamp outputs (Y17, Y20) turn on for 1 second maximum when the state changes to Run state. Take operation of connected components into consideration.

LEDs

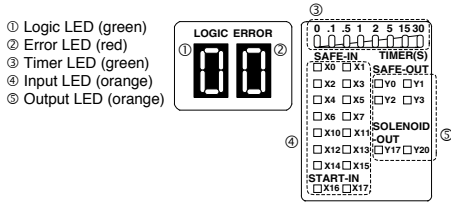

Logic LED ①

Type	LED	Status	Description
FS1A-C01S	1, 2, 3, 4, 5, 6, 7, 8	ON	The selected logic is in Run or Protection state
		Blink	The selected logic is in Configuration state
FS1A-C11S	1, 2, 3, 4, 5, 6, 7, 8, A, b, C, d	ON	The selected logic is in Run or Protection state (Ex. Logic 14A: 4→A→4→A→4→...)
		Blink	The selected logic is in Configuration state (Ex. Logic 14A: 4→A→OFF→A→4→OFF...)
FS1A-C01S/ C11S	E	Blink	The selected logic has Configuration error (logic not selected, or multiple logics are selected)
	Random	ON/Blink	Initializing (Initial state)
	OFF	OFF	Error (Stop state)

FS1A-C01S setting

Correct: Selecting one logic from 1 to 8
 Wrong: Selecting two or more logics from 1 to 8

FS1A-C11S setting

Correct: Selecting one logic from 1 to 8
 Selecting one from 1 to 4, and one from A, b, C, or d.
 Wrong: Selecting three or more logics from 1 to 8
 Selecting two or more logics from 1 to 4
 Selecting two or more logics from A (5), b (6), C (7), or d (8)

Error LED ②

Type	LED	Status	Description	
FS1A-C01S/ FS1A-C11S	1	ON	Input monitor error (Protection state)	
	2	ON	Wiring error at safety input or an error in safety input circuits	
	3	ON	Wiring error at start input or an error in start input circuit	
	4	ON	Wiring error at safety output or an error in safety output circuit	
	5	ON	Muting lamp error (disconnection) (FS1A-C01S: logic 4 only) (FS1A-C11S: logic 11d only)	
	6	ON	Power supply error or internal power supply circuit error	
	7	ON	Internal error, power supply error, or internal power supply circuit error	
	9	ON	EMC disturbance	
	C		ON	Configuration procedure is in progress (Configuration state)
			Blink	Configuration is valid (Note) (Configuration state)
	Random	ON/Blink	Initializing (Initial state)	
	OFF	OFF	Normal operation (Run state)	



Note: Blinks for 1 to 5 seconds after the enter button is pressed. Releasing the button during blinking activates the setting. The blinking LED becomes ON if the button is pressed for more than 5 seconds, and the setting becomes invalid even after the button is released.

Timer LED ③

Type	LED	Status	Description
FS1A-C01S/ FS1A-C11S	0	ON	No off-delay (safety outputs shut down immediately)
	.1	ON	Off-delay timer 0.1s
	.5	ON	Off-delay timer 0.5s
	1	ON	Off-delay timer 1s
	2	ON	Off-delay timer 2s
	5	ON	Off-delay timer 5s
	15	ON	Off-delay timer 15s
	30	ON	Off-delay timer 30s
	Each LED	Blink	Selected timer value (Configuration state)
	Random	ON/Blink	Initializing (Initial state)
	All LEDs	OFF	Timer value is not selected or the SafetyOne is in Stop state

LEDs, con't

- ① Logic LED (green)
- ② Error LED (red)
- ③ Timer LED (green)
- ④ Input LED (orange)
- ⑤ Output LED (orange)

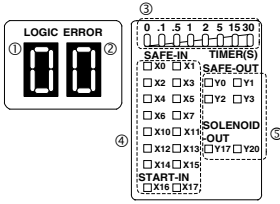

Input LED ④

SAFE-IN (X0 to X15), START-IN (X16, X17)

Type	LED	Status	Description
FS1A-C01S	X0 to X15	ON	Input ON
		OFF	Input OFF, Stop/Configuration state
		Blink	Input monitor error
	X16, X17	ON	Input ON
		OFF	Input OFF, Stop/Configuration state
		Blink	Input error (error displayed on error LED)
FS1A-C11S	X0 to X15	ON	Input ON
		OFF	Input OFF, Stop/Configuration state
		Blink	Input error (error displayed on error LED)
	X16, X17	ON	Input ON
		OFF	Input OFF, Stop/Configuration state
		Blink	Input error (error displayed on error LED)

Output LED ⑤

SAFE-OUT (Y0 to Y3), SOLENOID-OUT (Y17, Y20)

Type	LED	Status	Description
FS1A-C01S	Y0 to Y3	ON	Output ON
		OFF	Output OFF, Stop/Configuration state
		Blink	Off-delay operating
	Y17, Y20	ON	Output ON
		OFF	Output OFF, Stop/Configuration state
		Blink	Off-delay operating, or output error (error displayed on error LED)
FS1A-C11S	Y0 to Y3	ON	Output ON
		OFF	Output OFF
		Blink	Off-delay operating, or output error (error displayed on error LED)
	Y17, Y20	ON	Output ON
		OFF	Output OFF
		Blink	Off-delay operating, or output error (error displayed on error LED)

Overview

XW Series E-Stops

Interlock Switches

Enabling Switches

Safety Control

Light Curtains

AS-Interface Safety at Work

Configuration Switches

• FS1A-C01S

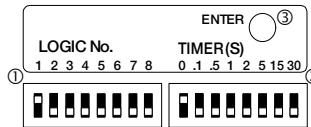

① Logic Switch ② Timer Switch ③ Enter button

• FS1A-C11S

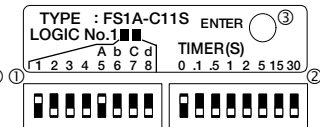

Logic Switch ①

FS1A-C01S

Eight DIP switches are provided for selecting a logic by moving a switch upward. For details, see user's manual "Chapter 5 Logic." Only one logic switch can be selected.

DIP Switch	1	2	3	4	5	6	7	8
Logic	001	002	003	004	005	006	007	008

FS1A-C11S

Eight DIP switches are provided for selecting a logic by moving one or two switch(es) upward. For details, see user's manual "Chapter 5 Logic."

DIP Switch	1	2	3	4	5	6	7	8
Logic	001	002	003	004	005	006	007	008
	1 + A	1 + b	1 + C	1 + d	2 + A	2 + b	2 + C	2 + d
	11A	11b	11C	11d	12A	12b	12C	12d
	3 + A	3 + b	3 + C	3 + d	4 + A	4 + b	4 + C	4 + d
	13A	13b	13C	13d	14A	14b	14C	14d

Timer Switch ②

Eight DIP switches are provided for selecting an off-delay timer value, by moving a switch upward. Only one timer switch can be selected.

Switch No.	Timer Value	Description
1	0	No off-delay (safety outputs shut down immediately)
2	.1	Off-delay timer 0.1s
3	.5	Off-delay timer 0.5s
4	1	Off-delay timer 1s
5	2	Off-delay timer 2s
6	5	Off-delay timer 5s
7	15	Off-delay timer 15s
8	30	Off-delay timer 30s

Enter Button ③

The enter button is used to activate the configuration of logic and timer switches. Error LED will blink for 1 to 5 seconds after pressing the enter button. Releasing the button during blinking activates the setting. The blinking LED becomes ON if the button is pressed for more than 5 seconds, and the setting becomes invalid even after the button is released. For setting the switches and enter button, use the setting tool supplied with the Safety-One.

Connector Specifications

Input Connector

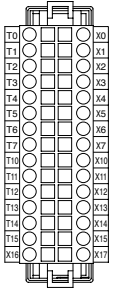

Applicable connector

- Spring clamp (30-pin)
FS9Z-CN01 (IDEC)
2-1871940-5
(Tyco Electronics)
- Crimp (30-pin)
2-1871946-5
(Tyco Electronics)

Terminal	No.	Description
T0	A1	Safety input drive terminal 0
T1	A2	Safety input drive terminal 1
T2	A3	Safety input drive terminal 2
T3	A4	Safety input drive terminal 3
T4	A5	Safety input drive terminal 4
T5	A6	Safety input drive terminal 5
T6	A7	Safety input drive terminal 6
T7	A8	Safety input drive terminal 7
T10	A9	Safety input drive terminal 10
T11	A10	Safety input drive terminal 11
T12	A11	Safety input drive terminal 12
T13	A12	Safety input drive terminal 13
T14	A13	Safety input drive terminal 14
T15	A14	Safety input drive terminal 15
T16	A15	Start input terminal 16
X0	B1	Safety input receive terminal 0
X1	B2	Safety input receive terminal 1
X2	B3	Safety input receive terminal 2
X3	B4	Safety input receive terminal 3
X4	B5	Safety input receive terminal 4
X5	B6	Safety input receive terminal 5
X6	B7	Safety input receive terminal 6
X7	B8	Safety input receive terminal 7
X10	B9	Safety input receive terminal 10
X11	B10	Safety input receive terminal 11
X12	B11	Safety input receive terminal 12
X13	B12	Safety input receive terminal 13
X14	B13	Safety input receive terminal 14
X15	B14	Safety input receive terminal 15
X17	B15	Start input terminal 17

Output Connector

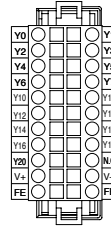

Applicable connector

- Spring clamp (22-pin)
FS9Z-CN02 (IDEC)
2-1871940-1
(Tyco Electronics)
- Crimp (22-pin)
2-1871946-1
(Tyco Electronics)

Terminal	No.	Description
Y0	A1	Safety output terminal 0
Y2	A2	Safety output terminal 2
Y4	A3	Safety output terminal 4
Y6	A4	Safety output terminal 6
Y10	A5	Safety output terminal 10
Y12	A6	Safety output terminal 12
Y14	A7	Safety output terminal 14
Y16	A8	Safety output terminal 16
Y20	A9	Solenoid/lamp output terminal 20
V+	A10	24V DC power terminal
FE	A11	Functional ground terminal
Y1	B1	Safety output terminal 1
Y3	B2	Safety output terminal 3
Y5	B3	Safety output terminal 5
Y7	B4	Safety output terminal 7
Y11	B5	Safety output terminal 11
Y13	B6	Safety output terminal 13
Y15	B7	Safety output terminal 15
Y17	B8	Solenoid/lamp output terminal 17
NC	B9	Blank terminal
V-	B10	0V DC power terminal
FE	B11	Functional ground terminal

Note: For the specifications of crimp connector, contact Tyco Electronics.

